

FLOW CHARACTERISTICS IN COMPOUND OPEN CHANNELS WITH ONE FLOODPLAIN

Nashat, A., Ali

Professor of Hydraulic and water resources, Civil Eng. Dept., Assuit Univ., Assuit 71516, Egypt.

Ali, A., Mohamed, Gamal AboZeid, and

Associate Prof., Civil Eng. Dept., Assuit Univ., Assuit 71516, Egypt

Wael, E., Mohamed

Demonstrator, Civil Eng. Dept., Assuit Univ., Assuit 71516, Egypt

(Received June 4, 2007 Accepted July 9, 2007)

This study is concerned with the flow characteristics in compound channels aiming to predict an accurate method for estimating the discharge passing through compound sections. Also it is aiming to study the flow characteristics of compound sections and trying to develop formula defining the flow behavior and its dynamics at compound sections. The study is performed experimentally in a rectangular compound section having a single floodplain. The height of main channel is changed twice to take 9cm and 15 cm. The channel bed slope is changed between 0.00243 up to 0.0037. The roughness of the channel bed is changed twice. The discharge is changed to give a range of Froude number between 0.12 and 0.73. The ratio of floodplain depth to the main channel one (df/dm) is changed to take values between 0.22 and 0.78. Vertical photos are taken to define the lateral velocity directions. The velocity is measured by a calibrated current meter. The actual discharges are measured by means of a calibrated nozzle – meter. The results revealed that the interaction between floodplain and main channel is minimum at a horizontal plain having a level equal to 0.4 floodplain depth (0.4df). The best subdivision used for discharge estimation with minimum error is found at this level. It is found that, the capacity of compound section increases in a linear relationship with the ratio of floodplain depth to that of main channel.

KEYWORDS: *Compound Channel, Discharge Assessment, Flow Characteristics.*

NOMENCLATURE					
A_{fp}	cross-sectional area of floodplain	L^2	S	longitudinal bed slope of the channel	—
A_{mc}	cross-sectional area of main channel	L^2	U	total calculated mean velocity	LT^{-1}

A_T	the total cross-sectional area of flow	L^2	U'^*	shear velocity due to skin friction or grain roughness (gR'S) 1/2	LT^{-1}
b	total channel width (b_r+b_m)	L	u	measured local velocity at distances (X and Z)	LT^{-1}
b_f	width of floodplain	L	V	calculated depth average velocity	LT^{-1}
b_m	width of main channel	L	v	depth average velocity	LT^{-1}
D	total flowing depth (d_r+d_m)	L	W	measured lateral velocity at distances (X and Z)	LT^{-1}
d_f	floodplain total water depth	L	w	weight of control volume	M
d_m	height of floodplain bed level from main channel bed level	L	X	lateral distance measured from floodplain wall	L
F_{fp}	floodplain boundary shear force per unit length	MLT^{-2}	x''	a function of ks/δ	—
F_{mc}	Main channel boundary shear force per unit length	MLT^{-2}	Y	local depth measured from floodplain bed level	L
g	the gravitational acceleration	LT^{-2}	Z	local depth measured from main channel bed level	L
K	roughness height	L	δ	boundary-layer thickness	L
K_s	equivalent grain roughness	L	γ	specific weight of water	$ML^{-2}T^{-2}$
P_a	perimeter of interface between main channel and floodplain	L	μ	absolute viscosity, and g is the gravitational acceleration	$ML^{-1}T^{-1}$
P_{fp}	Wetted perimeter of floodplain	L	ν	kinematic viscosity	L^2T^{-1}
P_{mc}	Wetted perimeter of main channel	L	ρ	liquid density	ML^{-3}
Q_c	total calculated discharge	L^3T^{-1}	τ_a	apparent shear stress	$ML^{-1}T^{-2}$
Q_m	total measured discharge	L^3T^{-1}	τ_{fp}	floodplain boundary shear stress	$ML^{-1}T^{-2}$

Q_{main}	measured discharge at main channel (discharge at the zone below the junction)	L^3T^{-1}	τ_{mc}	Main channel boundary shear stress	$ML^{-1}T^{-2}$
R	hydraulic radius (A/P)	L	τ_0	average shear stress over the cross section	$ML^{-1}T^{-2}$
R'	hydraulic radius due to grain roughness	L	τ'	drag force due to grain roughness	$ML^{-1}T^{-2}$

INTRODUCTION

Over the years, considerable research has been undertaken to investigate flow in compound channels, aimed at understanding the structure of flow and at the development of accurate methods of discharge estimation [1-13]. Experimental investigation by Myers [1], Wormleaton et al. [2], Knight and Demetriou [3] and Mohamed [4] displayed the boundary shear stress distribution to quantify the momentum transfer mechanism in terms of apparent shear force acting on the main channel/floodplain interface. Rajaratnam and Ahmadi [5] presented a laboratory study of the interaction between the main channel and flood-plain flows for a straight smooth main channel. Accordingly empirical relationships have been developed to express the apparent shear stress (Myers et al, [6]). The flow resistance in compound channel was investigated by Myers and Brennen [7], Ali and Mohamed [8] and Lambert and Sellin [9]. The major area of uncertainty in river channel analysis is that of accurately predicting the capability of river channels with floodplains. Martin and Myers [10] stated that conventional methods of discharge estimation for compound river channels were shown to have an error of up to $\pm 25\%$. Recent investigations carried out by Cassells et al. [11], Knight and Brown. [12] and Lyness et al. [13] have focused on discharge prediction in straight mobile bed compound channels, examining the impact of sediment movement in the main channel on the discharge capacity of both the main channel and floodplain. The most commonly used method for calculating discharge in compound channels is the divided channel method (DCM) in which the compound cross-section is divided into hydraulically homogeneous sub-areas (Bousmar and Zech, [14]). Lambert and Myers [15] developed a new approach, termed the weighted divided channel method (WDCM). In which the location of the main channel and floodplain interface is variable and dependent upon a weight coefficient. This coefficient is used to improve the estimation of mean flow velocity in both the main channel and the floodplain. The single channel method (SCM) is a simple model of computing uniform flow in a compound channel. In this model the channel is treated as a single unit with some appropriate averaging for the friction coefficient. The composite character of the channel is discarded and the velocity is assumed to be uniform in the whole cross-section. Using experimental observations and data from a natural compound river channel, Myers et al. [16] showed that the (SCM) significantly' underestimates the compound discharge for low flow depths.

In this paper, the characteristics of flow in compound channel with single floodplain are investigated. Based on the experimental and theoretical approaches the

flow is depicted and a method of accurate estimation of discharge in compound channel is proposed and verified.

EXPERIMENTAL SET-UP

Experiments were performed in a tilting flume of rectangular cross-section 300 mm wide 300 mm height and 13.5 m total length with 10.0 m length of glass sides and steel painted bed. The flow was made re-circulatory by using a centrifugal pump. The apparatus is shown schematically in Fig. 1. The flow rates were regulated by means of a gate valve located in the delivery pipe and was measured by a calibrated nozzle meter. The required compound cross section is formed by a wooden block with 15*15 cm and 15*9 cm in cross section (see Fig.(2)) and 11.50 m in length. The upstream end of the block was made sloped to decrease the inlet disturbances of the flow. The block was coated by water proof chemical material to prevent wood absorption of water. To take measurements of the longitudinal velocities, a calibrated current-meter was used. A digital camera (resolution 3.5 Mpix with macro option 25-30 cm) was used to take vertical photos (6 photos/minute) for determining the direction of lateral currents which impinged from main channel to floodplain or vice versa.

Tuff method with the digital camera and using ACAD programs were used for the determination of lateral velocity directions and values.

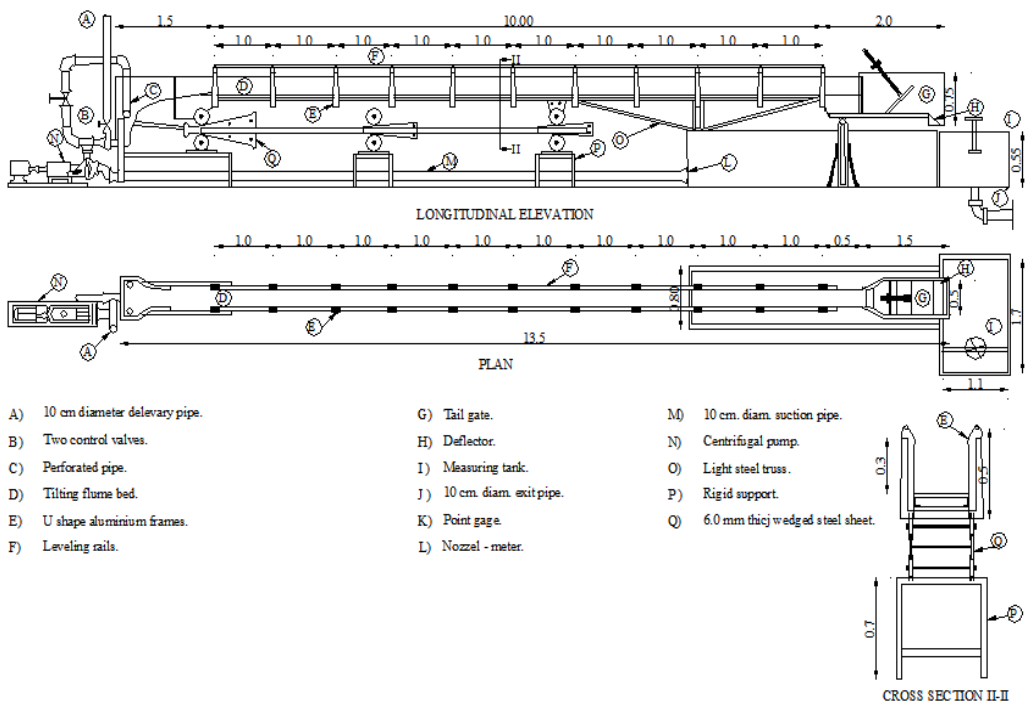

Fig. 1: Schematic representation of the experimental set-up

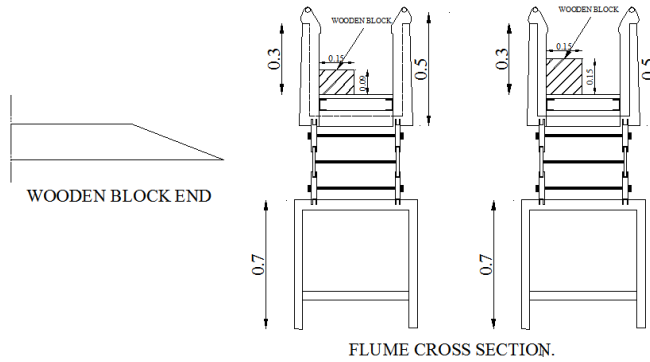

Fig. 2: Cross sections and inlet end of wooden block cross section

DIMENSIONAL ANALYSIS

The variables considered to investigate flow through compound channels include: total channel width b , width of floodplain b_f , width of main channel b_m , total flowing depth D , Floodplain total water depth d_f , height of floodplain bed level from main channel bed level d_m , roughness height K , longitudinal bed slope of the channel S , lateral distance measured from floodplain wall X , local depth measured from floodplain bed level Y , local depth measured from main channel bed level Z , total calculated discharge Q_c , total measured discharge Q_m , measured discharge at main channel (discharge at the zone below the junction) Q_{main} , total calculated mean velocity U , shear velocity over the compound section U^* , measured local velocity at distances (X and Z) u , calculated depth average velocity V , measured lateral velocity at distances (X and Z) W , apparent shear stress τ_a , average shear stress over the cross section τ_0 , liquid density ρ , absolute viscosity μ and g is the gravitational acceleration.

From these parameters, one can have the following functional relationships;

$$\Phi(b, b_f, b_m, D, d_f, d_m, Y, S, X, Z, Q_c, Q_m, U, V, \tau_a, \tau_0, \rho, \mu, g) = 0 \quad (1)$$

Using the dimensional analysis and applying their properties, one can have:

$$(V/U \text{ or } Q_c/Q_m \text{ or } Q_m/Q_{main} \text{ or } \tau_a/\tau_0) = \Phi(d_f/d_m, X/b, S, U, \rho, D/\mu,) \quad (2)$$

In which U/\sqrt{gD} is the Froud number F_e , $U, \rho, D/\mu$ is the Reynolds number (R_e). In open channel flow R_e has insignificant effect [17 and 18], so it may be dropped from Eq. (2). So Eq. (2) may be written as:

$$(V/U \text{ or } Q_c/Q_m \text{ or } Q_m/Q_{main} \text{ or } \tau_a/\tau_0) = \Phi(d_f/d_m, X/b,) \quad (3)$$

THEORETICAL BACKGROUND

For any regular prismatic channel under uniform flow conditions, the total retarding shear force acting upon the wetted perimeter is equal to the component of the gravity force in the direction of the flow. The gravity force component over unit length of channel is given by:

$$F = w \sin\theta = \gamma A_T S \quad (4)$$

For a typical compound channel, the boundary shear force per unit length is given by:

$$F = F_{mc} + F_{fp} = (\tau \times P)_{mc} + (\tau \times P)_{fp} \tag{5}$$

Equations (4) and (5) must be balanced overall for any compound section. Moreover, the equilibrium between boundary shear and gravity forces must hold for any subdivision of the compound channel (see Figs. (3) and (4)). For the shown subdivisions, a part of the boundary shear force is provided by that acting upon the interface between the adjacent subdivisions. This force, F_a was termed the apparent shear force as shown in Figs. (4a and 4b). It was selected due to the result of lateral velocity. At this force, both the lateral velocity and percentage error of discharge (%error in Q) tend to be zero at any interface between main channel and floodplain after assuming that the vertical interaction also equal zero at that interface. Substituting A_{mc} for cross sectional area of the compound channel A_T in Eq. (1), and assuming the difference between the forces in Eqs. (4) and (5) equals to the apparent shear force, the following expression for the apparent shear stress may be obtained;

$$\tau_a = \frac{1}{P_a} (\gamma \times A_{mc} \times S - (\tau \times P)_{mc} - (\tau \times P)_{fp}) \tag{6}$$

in which τ_a = the apparent shear stress acting upon the assumed interface which has a total length of P_a .

In Eq. (6), the values of A_{mc} , P_{mc} , can be easily obtained, for any interface location, from considerations of channel geometry and depth of flow. The value of the average boundary shear stress in the channel, τ_0 could be calculated over the section. An expression similar to Eq. (6) can be deduced from equilibrium considerations on floodplain subdivisions as in the following from;

$$\tau_a = \frac{1}{P_a} ((\tau \times P)_{mc} + (\tau \times P)_{fp} - \gamma \times A_{fp} \times S) \tag{7}$$

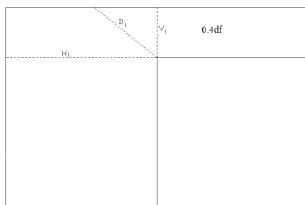
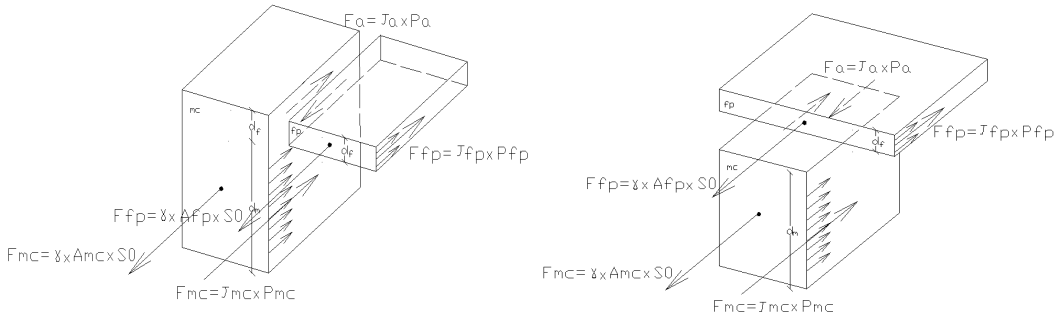

Fig. 3: Channel cross section showing alternatives interface planes



(a) Vertical interface (Vi) (b) Horizontal interface (Hi)
 Fig. 4: Exploded view of compound section showing forces acting on subdivisions

CALCULATION OF SHEAR STRESSES ON BOTH ROUGH AND SMOOTH COMPOUND CHANNELS

Rough compound channel: The shear stress acting along rough channel bed can be determinate by:

$$\tau' = \gamma S(R') \tag{8}$$

Yang [1⁹] suggested different methods for the determination of total roughness or resistance to flows. One of these methods expresses the resistance due to grain roughness or skin friction by:

$$U/U_* = 5.75 \log (12.27 (R'/K_s) x'') \tag{9}$$

The value of x'' depends on ks/δ [1⁹], where

$$\delta = 11.6\nu/ U_* \tag{10}$$

With the given values of U and x'' the value of R' can be computed.

smooth compound channel: Shear stress around the compound section could be easily calculated as follows:

$$\tau = \gamma S(R) \tag{11}$$

RESULTS AND DISCUSSIONS

Stage Discharge Curve: In both rough and smooth compound channels, the relation between total measured discharge in compound channels and water flow depth Z (stage discharge curve) are shown plotting in Fig. (5). Generally it could be observed that the discharge increases with the increase of water depth and this trend is the same for both rough and smooth compound channels. Also, it is seen from the figure that the increasing rate of discharge is faster for water depths (Z) greater than the main channel water depth. This means that, the floodplain increases the capacity of the compound section to pass discharges than the extended main channel only (see dash line on the figure. In addition, the effect of roughness is noticed where for the same value of water depth (Z) the discharge in smooth compound channel is greater than that in rough one. Also, the increase in bed slope increases the discharge for both cases of roughness.

Longitudinal Velocity Distributions: Figures (6) to (8) show the plot of local longitudinal velocities (u) against water depth (Z) values for horizontal different distances (X) from floodplain side wall at bed slope 0.0243 and different floodplain depth (d_f) respectively. It is seen from the figures that, the maximum value of velocity in floodplain increases with the increase of floodplain water depth and its value is always smaller than the maximum main channel velocity. This means that the main part of flow is mainly flowing in the main channel. Another observation from these figures is that the values of the velocities increase toward the center of main channel from the side walls but the rate of their increase are delayed at the area of interaction between floodplain and main channel due to the produced secondary currents.

Comparing the values of velocities for smooth compound channel with those for rough one results that, for rough floodplain the velocity near its level is smaller for same distance (X) than that for smooth one but it is greater in the lower part of main channel.

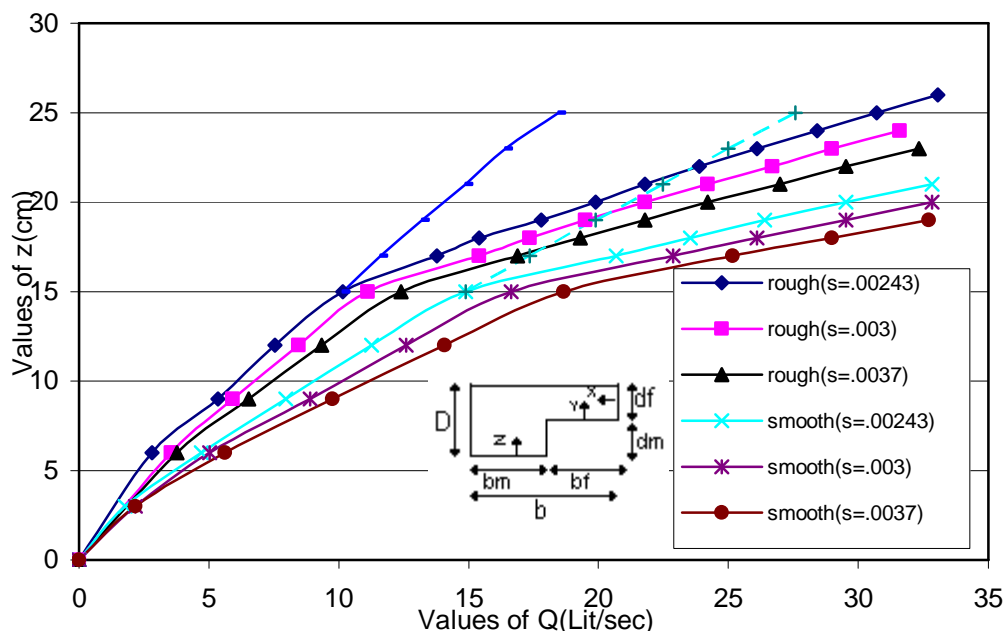

Fig. 5: Variation of measured flow rate Q with flow depth Z (stage discharge curve) for both rough and smooth compound channels at, $d_m=15\text{cm}$ with different bed slopes.

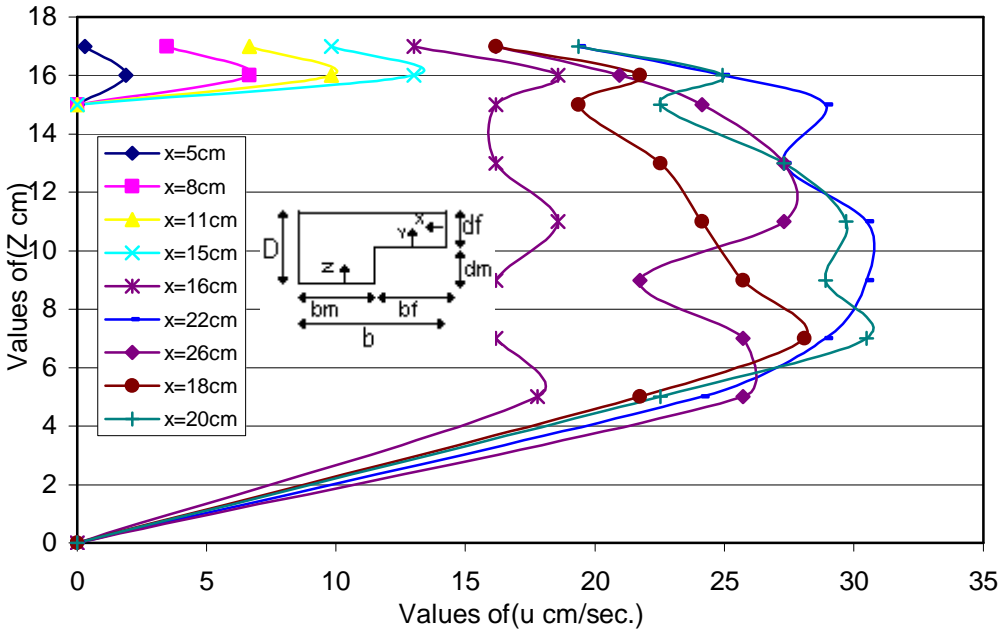

Fig. 6: Longitudinal velocity profiles for different X in case of **rough** compound channel, at $S=0.00243$, $d_m=15\text{cm}$ and $d_f=2\text{cm}$.

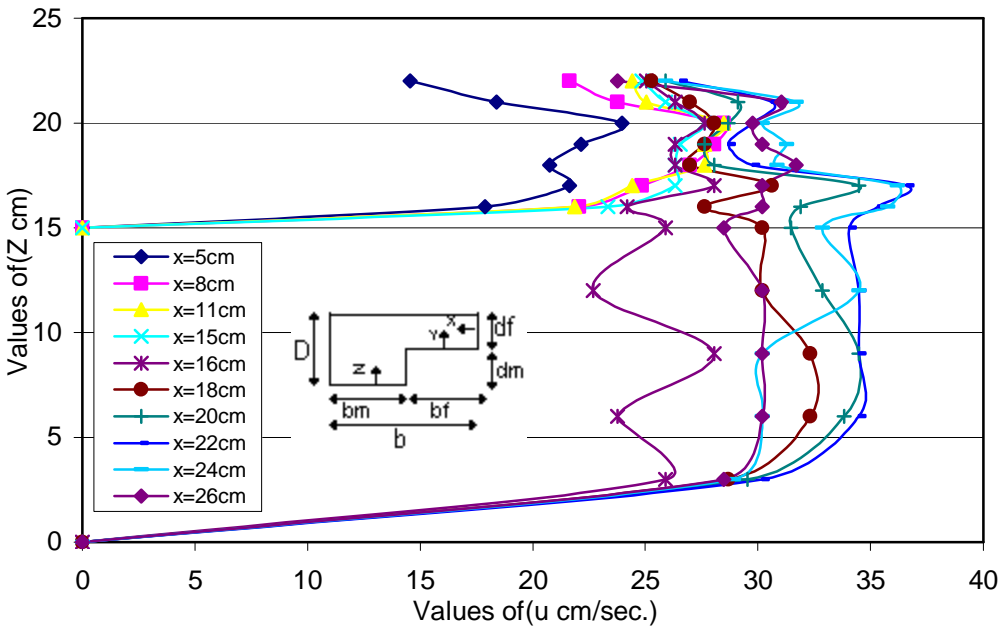

Fig. 7: Longitudinal velocity profiles for different X in case of **rough** compound channel, at $S=0.00243$, $d_m=15\text{cm}$ and $d_f=7\text{cm}$.

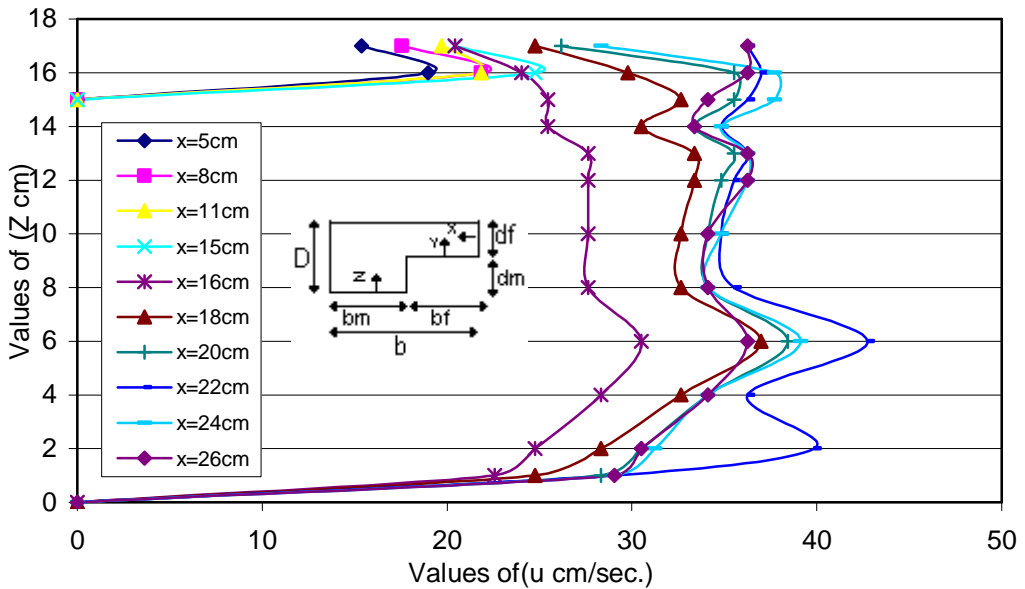

Fig. 8: Longitudinal velocity profiles for different X in case of **smooth** compound channel, at $S=0.00243$, $d_m=15\text{cm}$ and $d_f=2\text{cm}$.

Longitudinal Isovel Lines of the Velocities: The isovels lines of the longitudinal flow velocities are drawn in Figs. (9) through (12) for the two cases, rough and smooth compound channels, at different floodplain water depths. These isovels are drawn to study the longitudinal velocities characteristics in both rough and smooth compound channels. Also to discuss the effect of the relative floodplain water depth to the main channel water depth (d_f/d_m) on the isovels of the longitudinal velocities. The values of (d_f/d_m) which presented here are varied from 0.133 to 0.47 for both smooth and rough compound channel. Figs (9) and (10), the isovel lines of rough compound channel are presented. From these figures, it can be seen clearly that the max longitudinal velocities appeared to be around the horizontal centerline of main channel and almost located in the upper part of the deep channel. It's clearly seen from figures (11) and (12), case of smooth compound channel, that the maximum longitudinal velocities in the whole compound channel appeared to be near the vertical centerline and towards the lower half of the main channel.

Through figure (12) which the relative water depth is 0.47, case of smooth compound channel, it could be seen that there are more than one maximum velocity in different heights.

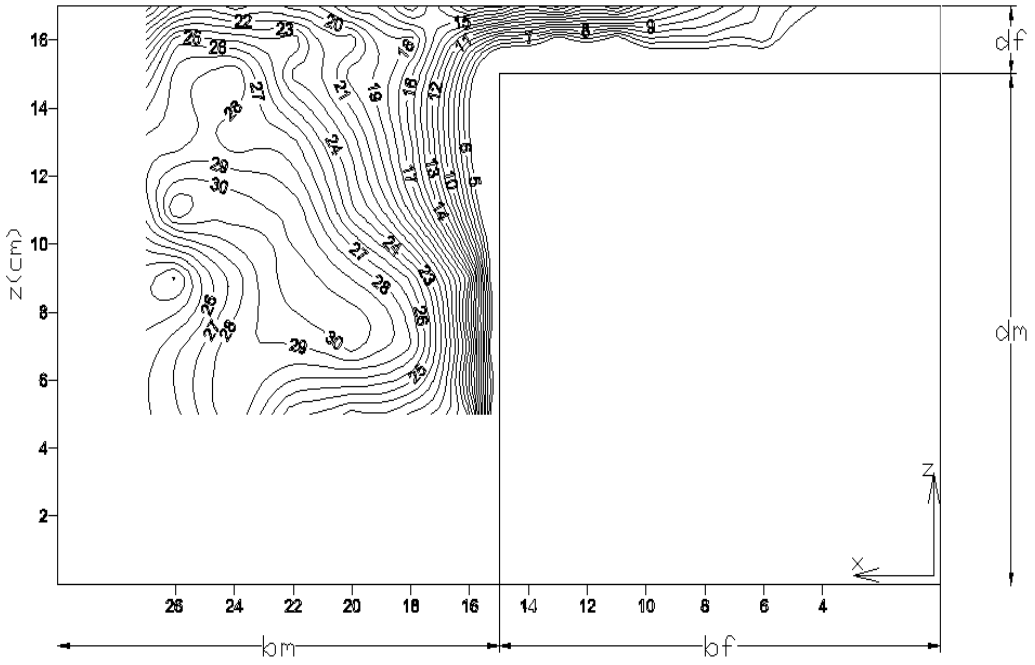

Fig. 9: Isovel lines for **rough** compound channel, at $S=0.00243, b_f=15\text{cm}, b_m=15\text{cm}, d_m=15\text{cm}$ and **$d_f=2\text{cm}$** .

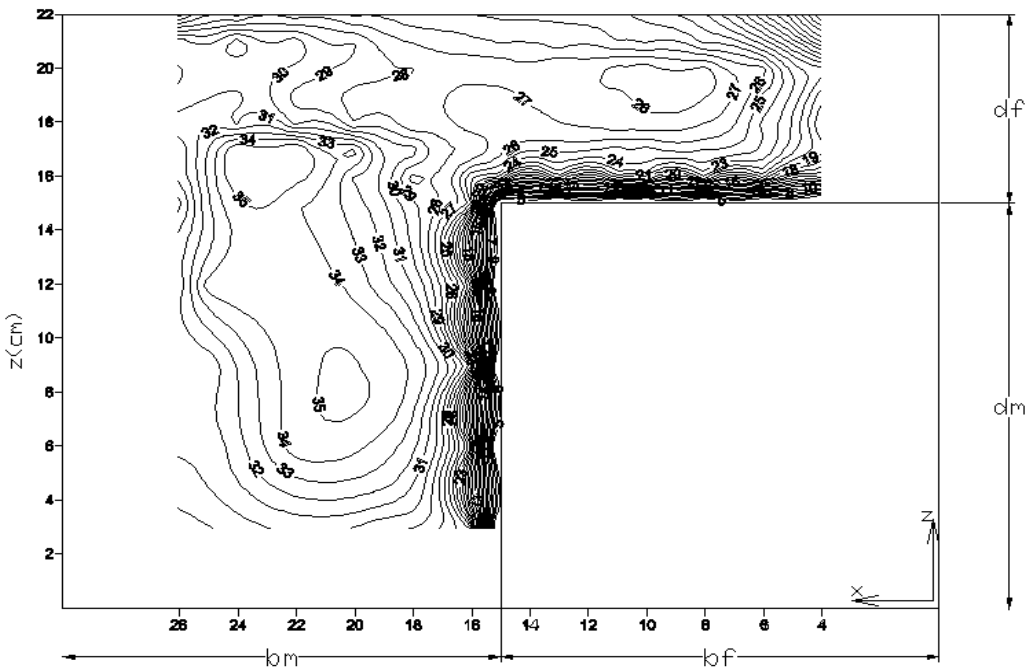

Fig. 10: Isovel lines for **rough** compound channel, at $S=0.00243, b_f=15\text{cm}, b_m=15\text{cm}, d_m=15\text{cm}$ and **$d_f=7\text{cm}$** .

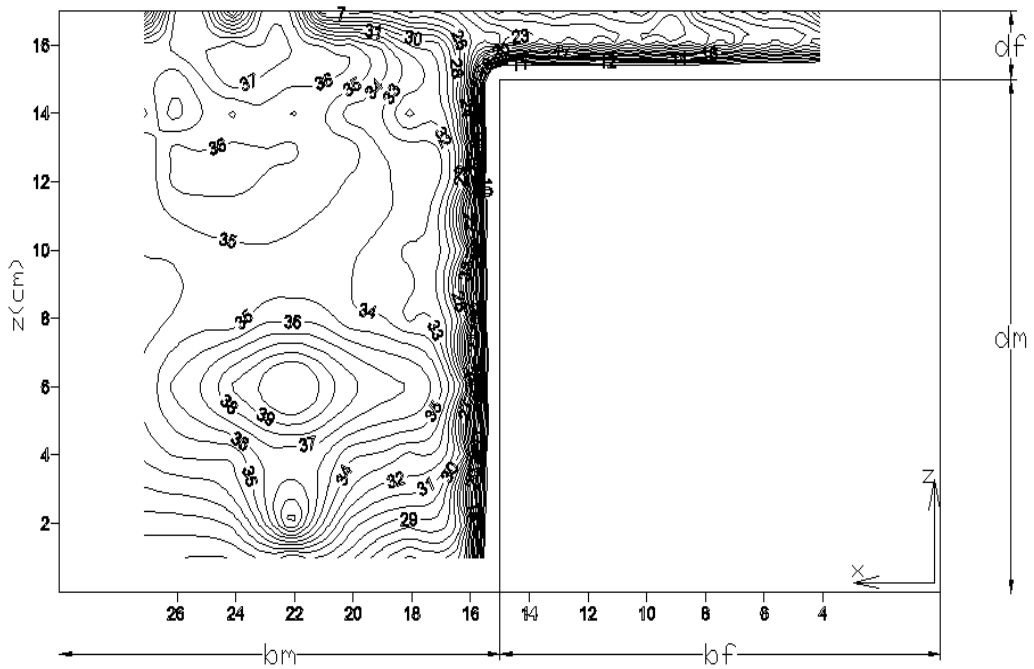

Fig. (11) Isovel lines for **Smooth** compound channel, at $S=0.00243$, $b_f=15\text{cm}$, $b_m=15\text{cm}$, $d_m=15\text{cm}$ and $d_f=2\text{cm}$.

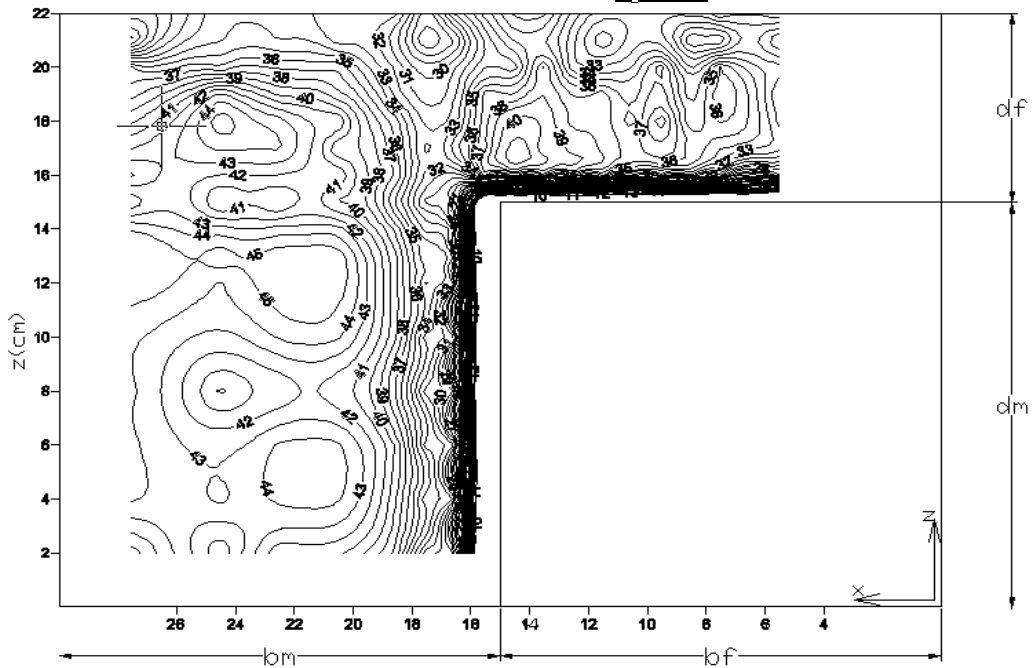

Fig. 12: Isovel lines for **Smooth** compound channel, at $S=0.00243$, $b_f=15\text{cm}$, $b_m=15\text{cm}$, $d_m=15\text{cm}$ and $d_f=7\text{cm}$.

Secondary Currents: Due to different hydraulic conditions prevailing in the main channel and floodplain, lateral vortices are generated. These lead to produce lateral currents from main channel to floodplain or vice versa. The produced lateral currents acted as a medium for momentum transfer between the main channel and floodplain (Patra and Kar [20]). So, the lateral directions of the currents are determined to clarify the conditions at which the momentum may transfer from or to main channel flow. Shown in Figs. (13) to (15) are the plot of the direction of lateral current caused due to the presence of floodplain for both rough and smooth compound channels and different flow conditions. It is seen on these figures that at shallow depths over floodplain, the directions of lateral currents take place from the main channel flow to floodplain leading to a decrease in the main channel longitudinal velocity (see Figs.(6 to 8)). A single surface vortex is appeared in floodplain. This process continues for certain depths of flow in the floodplain then two surface vortices are appeared one in main channel and the other in floodplain. As the depth of flow in the floodplain increases, the lateral currents are being from floodplain to main channel and the separated surface vortices are disappeared. In case of rough floodplain the lateral currents shifted upward. These results are in agreement with Patra and Kar [20].

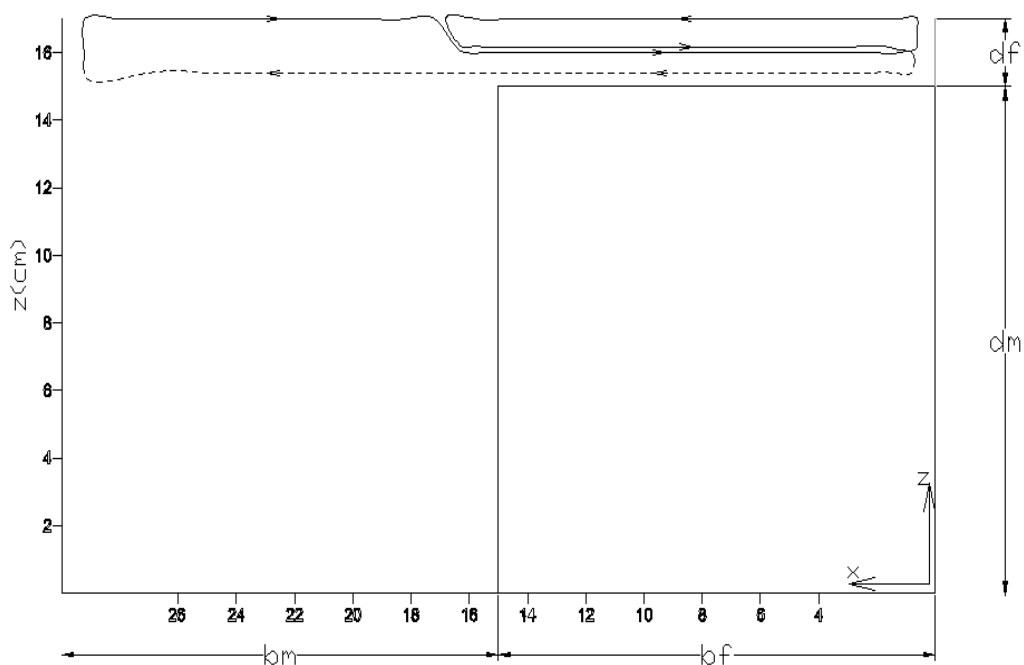

Fig. 13: Secondary currents directions for **rough** compound channel, at $S=0.00243$, $d_m=15\text{cm}$ and $d_f=2\text{cm}$.

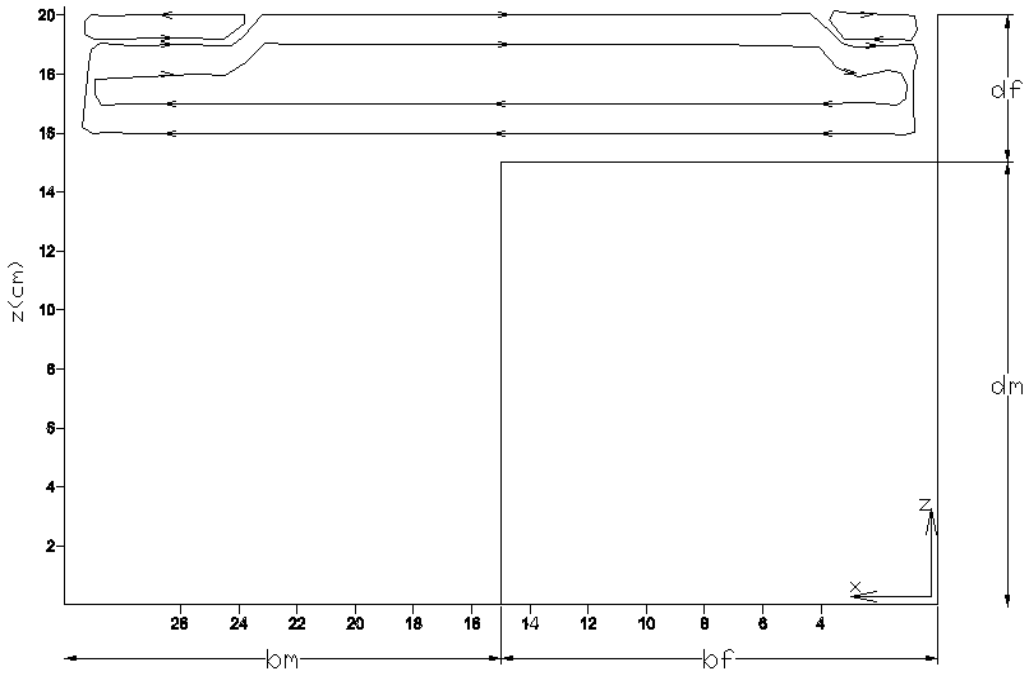

Fig. 14: Secondary currents directions for **rough** compound channel, at $S=0.00243$, $d_m=15\text{cm}$ and $d_f=5\text{cm}$.

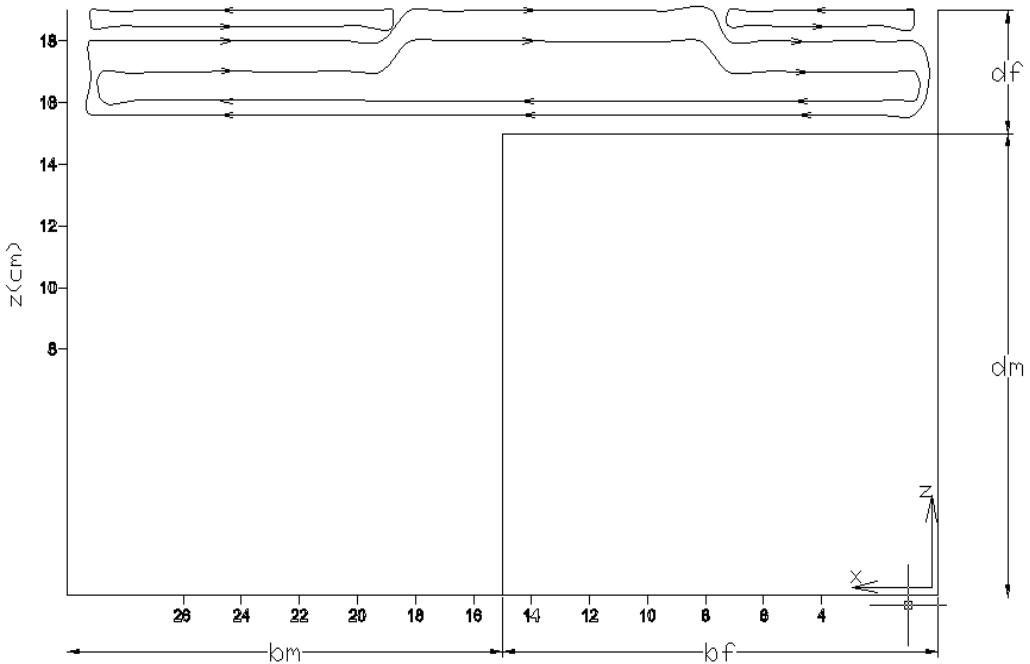

Fig. 15: Secondary currents directions for **smooth** compound channel, at $S=0.00243$, $d_m=15\text{cm}$ and $d_f=4\text{cm}$.

Lateral Velocity Distributions: In order to define the point at which the lateral current velocity equals to zero (point of separation between two velocity directions), the values of lateral velocities are plotted against the depth of floodplain as shown in Fig. (16) and Fig. (17) for both rough and smooth compound sections respectively. The negative sign of the values of (W) means the lateral current directions are from floodplain towards the main channel. It is seen, that there is one interface between the lateral currents (zero value of W) at water depth in floodplain equals to 0.4 of the total floodplain water depth. This means that one can take this level as an interface level to divide the section for calculating the discharge in compound channels as it will be discussed later.

Influence of floodplain on discharge capacity of compound section: In order to show the influence of the presence of floodplain in a compound channel on its capacity of passing discharge, the relative discharge Q_m/Q_{main} with the d_f/d_m ratio are shown plotting in Figs(18) for rough compound channel. From the figure, it's seen that the discharge in compound section is increased linearly with the increase of water depth in comparison with that of rectangular section for same water depth. This means in the range of the present experimental parameters that the compound section has a larger capacity for passing discharge than the single one for same water depth. Same results are obtained for smooth compound channel. It is seen from the figure that, both the bed slope and the channel height have no effect on (Q_m/Q_{main}) . The relationship between (Q_m/Q_{main}) and (d_f/d_m) may be represented by:

$$\left[\frac{Q_m}{Q_{main}} = 3.51\left(\frac{d_f}{d_m}\right) + 1 \right] R^2=0.995 \tag{9}$$

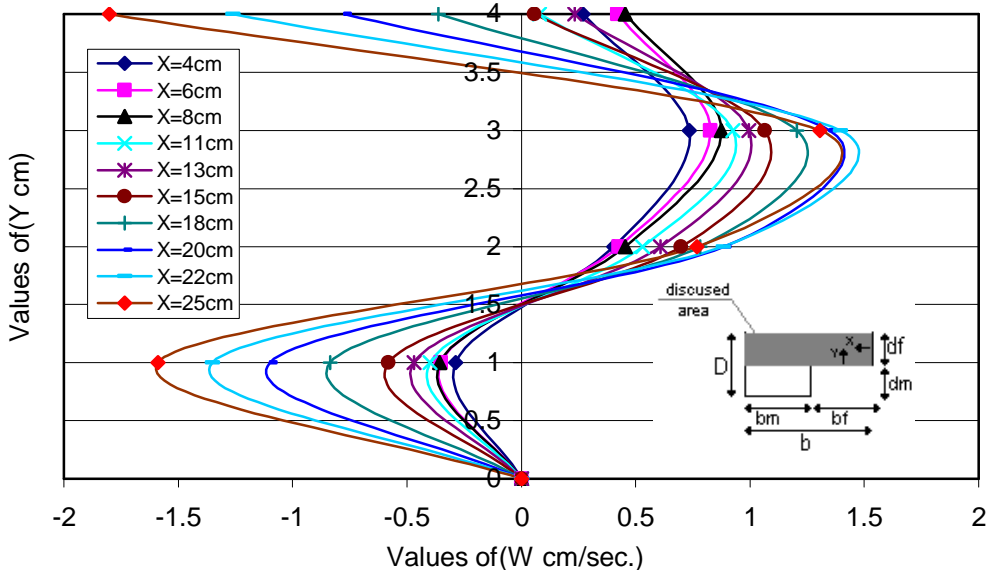

Fig. 16: Variation of W values with Y values for rough compound channel, with $S=0.00243$, $d_m=15\text{cm}$ and $d_f=4\text{cm}$.

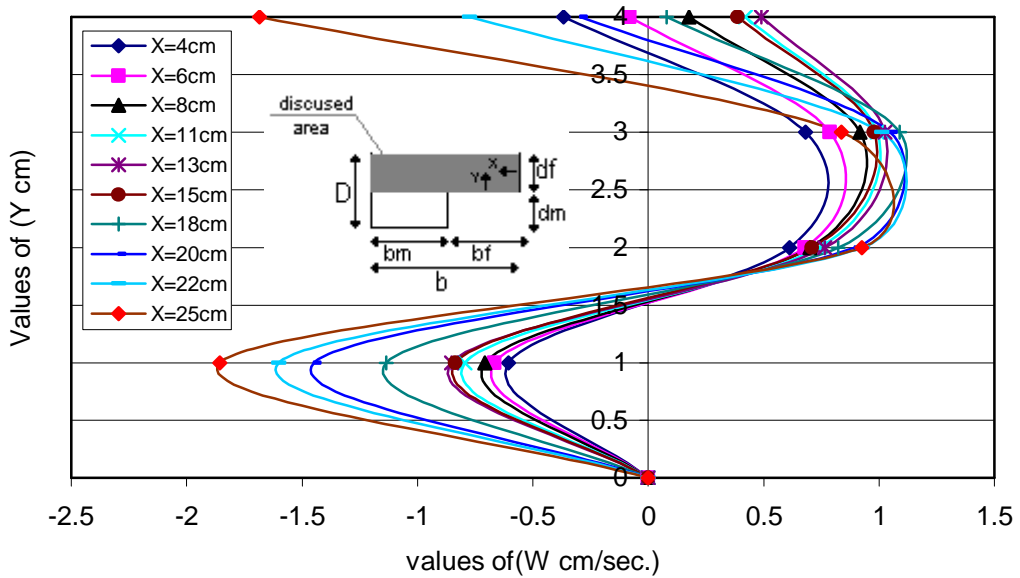

Fig. 17: Variation of W values with Y values for **smooth** compound channel, with $S=0.00243$, $d_m=15\text{cm}$ and $d_f=4\text{cm}$.

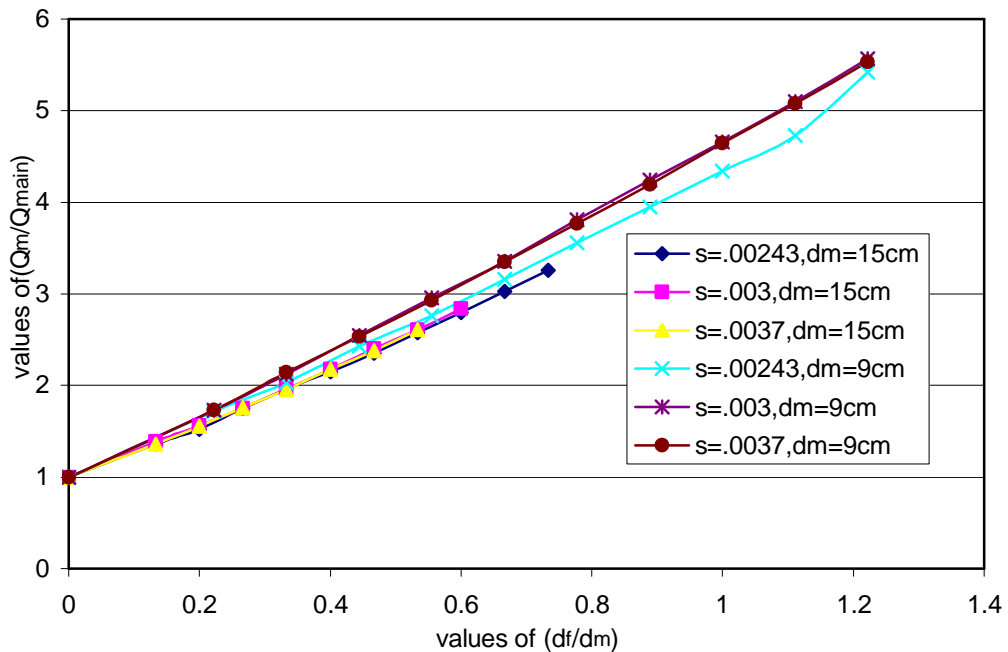

Fig. 18: Variation of (Q_m/Q_{main}) with (d_f/d_m) for different values of bed slope and d_m at rough compound section.

Depth average velocity: The characteristics of flow through a compound channel section may be represented by the ratio of depth average velocity (v) to the total compound section average velocity (U) at different lateral distance (X). The values of (v/U) are shown plotted against (X/b) for different floodplain depth (d_f/d_m) ratios in Fig.(19) for rough compound section . It is observed that the mean velocity over the vertical distance increasing slowly from the wall of floodplain to its end and then the rate of this increase being faster towards the center of main channel. At the interface of floodplain with main channel there is a jump in the mean value of the velocity over the depth. This jump is higher in case of shallow floodplain water depth. This may due to the lateral flow currents generated in this area. For all of (d_f/d_m) values, It is note that the local velocity (v) equals to ($0.95 U$) at (X/b) equals to 0.53 . Using the method of best fit and regression analysis an empirical relationship may be deduced and take the following form:

$$\frac{V}{U} = G\left(\frac{X}{b}\right)^4 + H\left(\frac{X}{b}\right)^3 + I\left(\frac{X}{b}\right)^2 + K\left(\frac{X}{b}\right) + L \quad (10)$$

Where G , H , I , K , L are constants and take the following values at table (1) shown below:

d_f/d_m	rough					
	G	H	I	K	L	R2
0.133	-18.99	13.983	9.9541	-5.654	0.6096	0.9862
0.20	-20.45	20.345	2.1755	-2.314	0.3383	0.9872
0.267	-34.53	68.44	-47.03	13.69	-0.505	0.9784
0.333	-43.13	81.286	-51.85	14.34	-0.731	0.9885
0.467	-24.62	38.367	-17.73	3.799	0.2559	0.9819

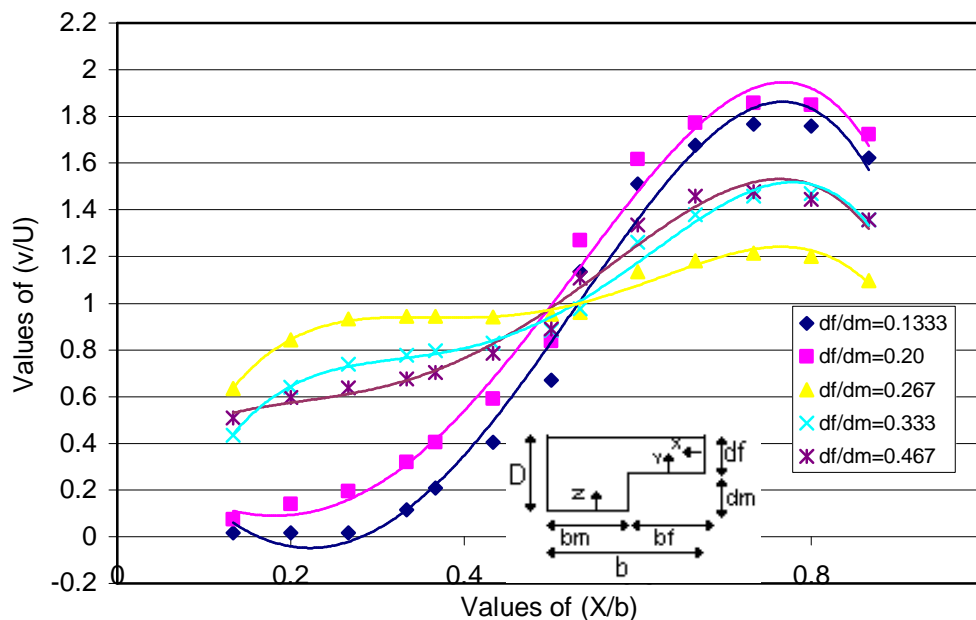

Fig. 19: Relation between values of v/U and X/b ratios at compound channel with rough floodplain, $S=0.0243$ and $d_m=15\text{cm}$.

Estimation of flow discharge: The conventional method of the calculating of the discharge in compound channel sections divides the channel into hydraulically homogeneous regions by plains originating from the junction of floodplain and main channel. So, the floodplain region can be considered as moving separately from the main channel. The assumed planes may be either of the following (see Fig. 3); (1) Vertical interface (V_i); (2) Horizontal interface (H_i); (3) Diagonal interface (D_i).

As was outlined earlier, the intention of the writers is to identify an accurate, simple, but practicable way of calculating discharge for all types of compound channels. To achieve this, the compound channel is divided into zones by preceding easily identifiable interface planes running from the floodplain-main channel junction. In all cases the interface length is not included in the wetted perimeter. Manning's equation is used to calculate the discharge carried out by each zone of the compound section individually, which when combined together gives the total discharge carried by the compound section. In the present study, the discharges are calculated for the following subdivisions; (i) Horizontal interface with floodplain level (H_i); (ii) Horizontal interface at $0.40d_f$ (H_{fi}); (iii) two horizontal interfaces one at the level of floodplain and the other at $0.40d_f$ (H_{fi}); (iv) vertical interface (v_i); and (v) Diagonal interface with angel of inclination 45 to the horizontal (D_i).

All the calculated discharge (Q_c) with these interfaces are plotted as a ratio of (Q_c/Q_m) against different (d_f/d_m) values as shown in Figs. (20) to (22) for both rough and smooth compound channel with $d_m=15\text{cm}$ and 9cm . The calculated discharges taking whole compound section with no interfaces (No. int.) are appeared in the figures for the comparison. It is observed that a slight increase in the value of the discharge ratio (Q_c/Q_m) with the increase of floodplain water depth for all cases of roughness and

interfaces. The best accuracy is observed with the horizontal interface (H_f) at which the values of $(Q_c/Q_m) \approx 1$, but with the other interfaces the values of (Q_c/Q_m) are less or more than unity. This accuracy is acceptable and is recommended for safety. The roughness doesn't affect the results. This result is comparable with the previously obtained from the lateral velocity distributions.

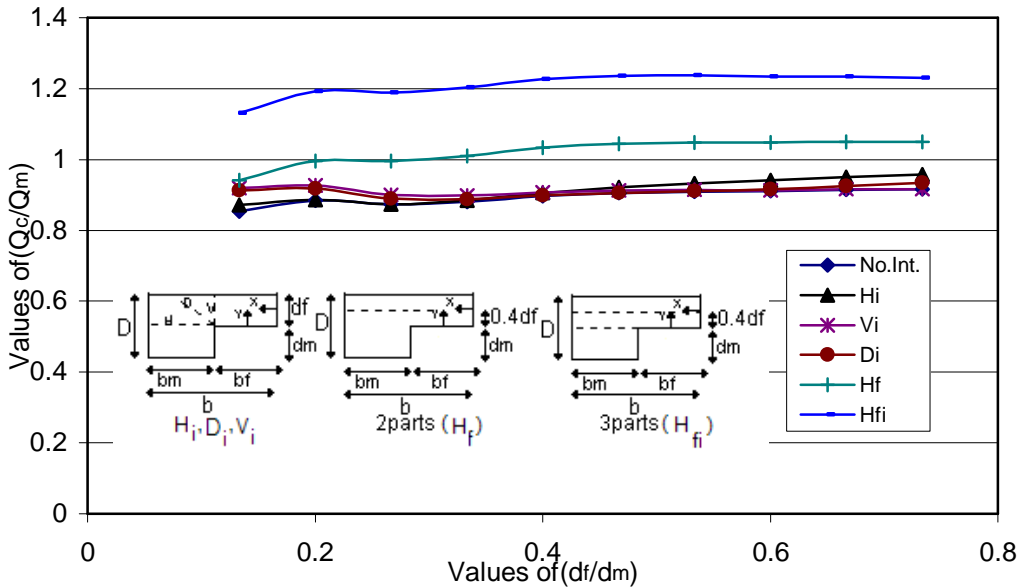

Fig. 20: Relationship between the values of d_f/d_m and (Q_c/Q_m) for different cases of Subdivisions with rough compound channel at $S=0.00243$, and $d_m=15\text{cm}$.

Verification of The Discharge Assessment Results: To verify the previous selection of the horizontal interface ($0.4d_f$), apparent shear stress is calculated as a ratio of the average boundary shear stress around the compound section (τ_a/τ_o) and compared with that at conventional horizontal interface (H_e). Figure (23) shows a comparison between (τ_a/τ_o) at both mentioned interfaces for both rough and smooth compound section, respectively. It seen clearly that the apparent shear stress at $0.4d_f$ is smaller than at H_i , although it increases with the increase of d_f . Confirming that the interface at $0.4d_f$ is a good choice for dividing the compound section.

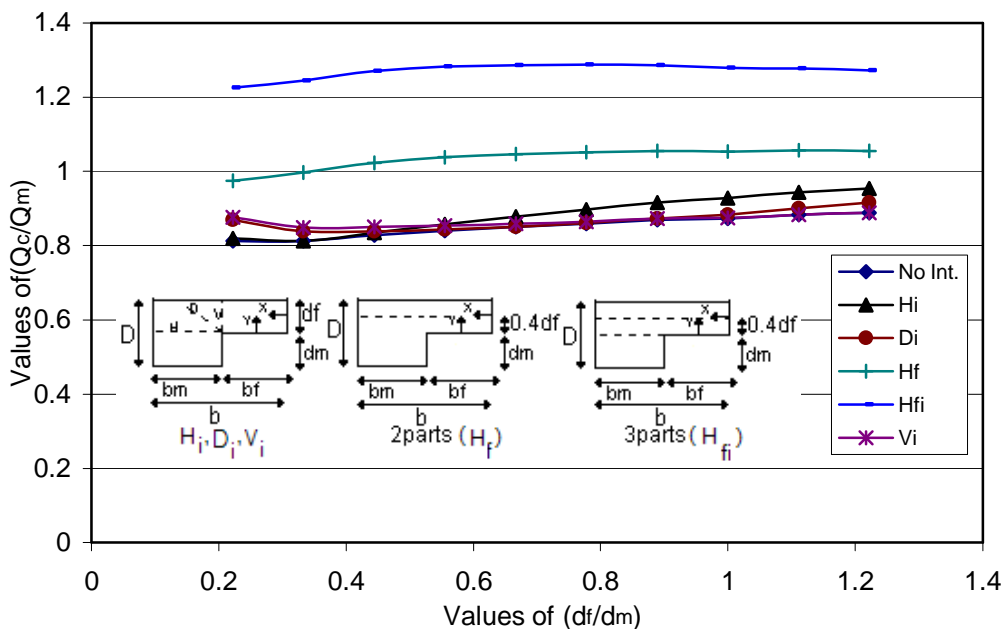

Fig. 21: Relationship between the values of d_f/d_m and (Q_c/Q_m) for different cases of subdivisions with rough compound channel at $S=0.0037$, and $d_m=9\text{cm}$.

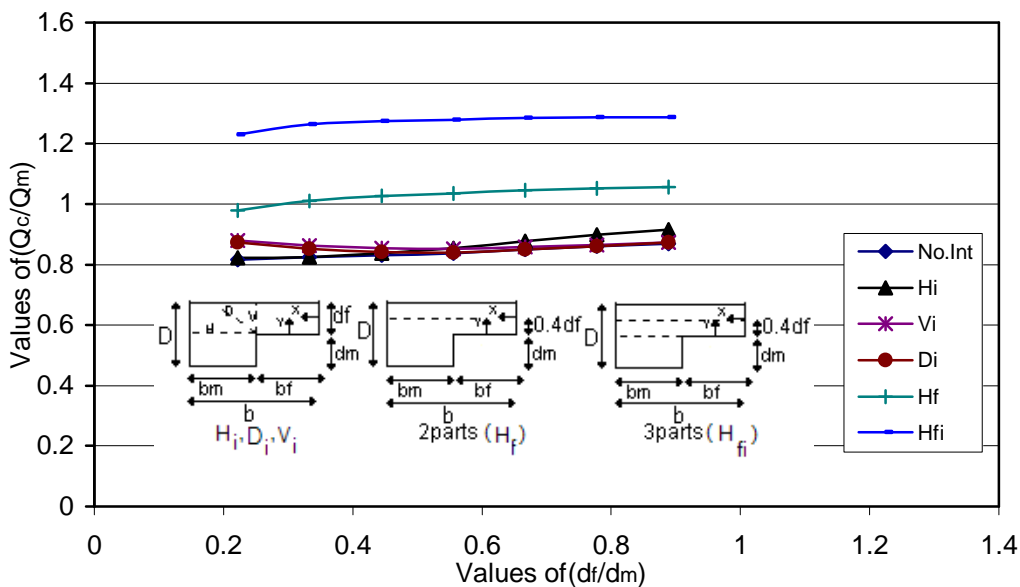

Fig. 22: Relationship between the values of d_f/d_m and (Q_c/Q_m) for different cases of Subdivisions with smooth compound channel at $S=0.00243$, and $d_m=9\text{cm}$.

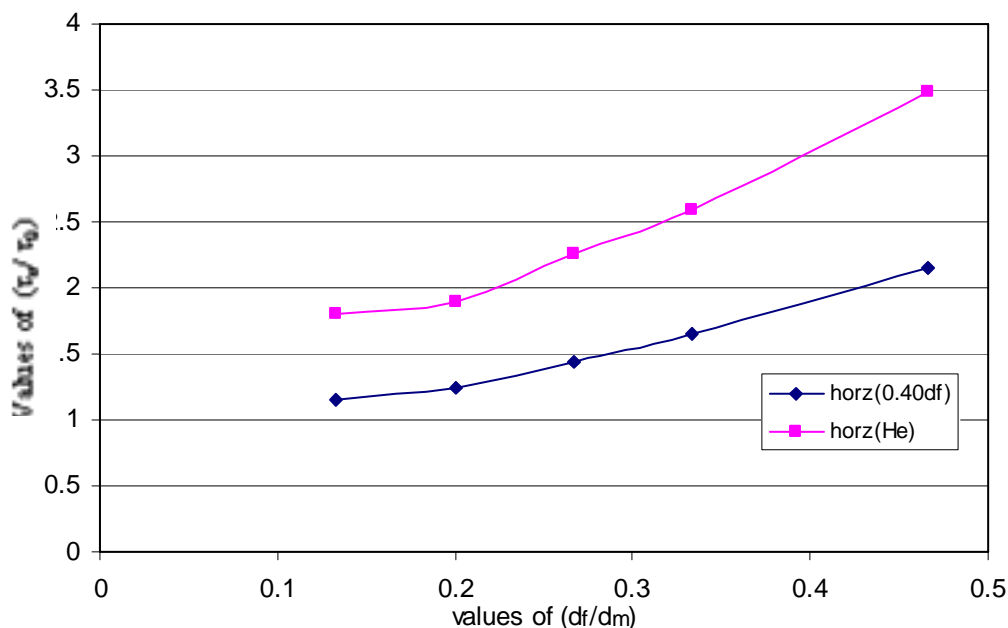

Fig. 23: Comparison between the ratio (τ_a/τ_o) for horizontal subdivision with different ratios of (d_f/d_m) for rough compound channel, at $S=0.00243$ and $d_m=15\text{cm}$.

Also, the total discharge passing through the compound section is calculated (Q_c) as follows; 1) the cross section is divided into vertical subsections and by integrating the velocity profiles, 2) by using Manning's equation for uniform flow at (H_f) subdivision. The values of these discharges (Q_c) are plotted against the total measured discharges (Q_m) for both rough and smooth compound sections as shown in Fig.(24). From the figure it's seen that, most of the points are colustrated the line of equilibrium. This confined the accuracy of the calculation of discharge by the mentioned methods.

CONCLUSIONS

From the analysis of both the theoretical and experimental results on the compound cross section of sloped-bed channel and for the range of the investigated parameters, the following main conclusions may be drawn:

1. The best subdivision found at which the discharge can be calculated accurately for compound channel is horizontal interface at $0.4 d_f$.
2. The characteristics of flow through compound channel with one floodplain are analyzed well.
3. Empirical relationships are developed defining the flow behavior and its dynamics for compound section.

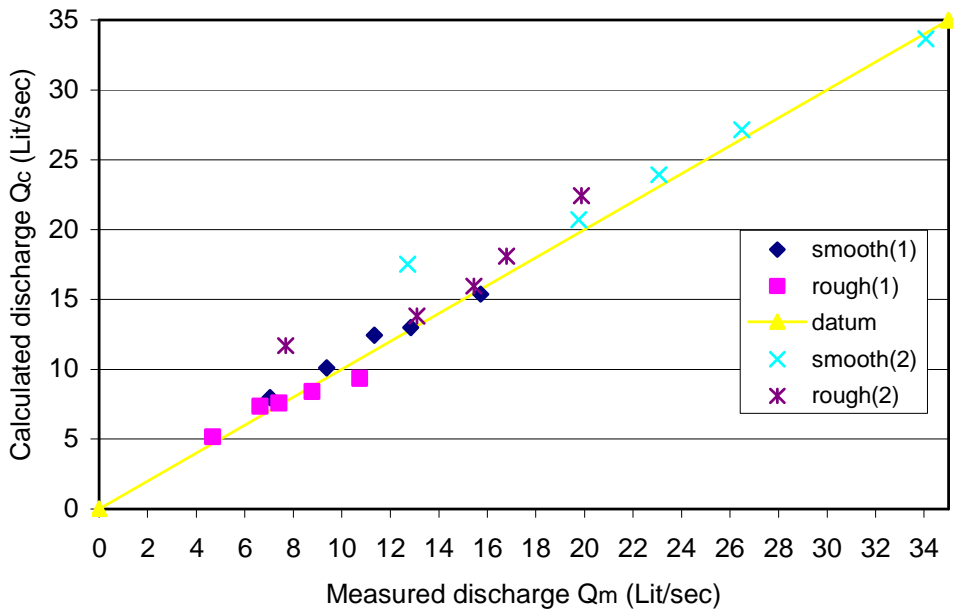

Fig. 24: Variation of the calculated discharge (Q_c) and the measured one at rough and smooth compound channel, with $S=0.00243$, $b_f=15\text{cm}$, $b_m=15\text{cm}$, $d_m=15\text{cm}$ and $d_f=2\text{cm}$.

REFERENCES

1. Myers, W.R.C., "Momentum Transfer in a Compound Channel". J. of Hyd. Res., Vol 16, 139-150, 1978.
2. Wormleaton, P.R., Alien, J. and Hadjipanos, P., "Discharge Assessment in Compound Channel Flow". J. of the Hyd. Div., ASCE, Vol 108, 975-994, 1982.
3. Knight, D.A. and Demetriou, J.D., "Floodplain and Main Channel Flow Interaction", J. of Hyd. Eng., ASCE, Vol 109, 1073-1092, 1983.
4. Mohamed, A. A. "Flow Characteristics in a Smooth Channel of Composite Section", Eng. Res. Bulletin, Vol 5, 282-300, 1991.
5. Rajaratnam, N., and Ahmadi, R. M., "Interaction between Main Channel and Flood Plain Flows," J. of the Hyd. Div., ASCE, Vol. 105, No.5, 573-587, 1979.
6. Myers, W.R.C., Knight, D.W., Lyness, J.F., Cassells, J.B. and Brown, F., "Resistance Coefficients for Inbank and Overbank Flows", Proc. Instn. Civ. Eng. Wat., Marit. & Energy, Vol. 136, 105-115, 1999.
7. Myers, W.R.C. and Brennen, E.K., "Flow Resistance in a Compound Channel", J. of Hyd. Res., Vol. 28, 141-146, 1990.
8. Ali, N. A. and Ali A. Mohamed " Computation of Flow Capacity in Compound Channel with Varying Roughness" Eng. Res. Bulletin, Vol 3,136-153, 1991.
9. Lambert, M.F. and Sellin, R.H.J., "Discharge Prediction in Straight Compound Channels Using the Mixing Length Concept", J. of Hyd. Res., Vol 34, 381-394, 1996.

10. Martin, L.A. and Myers, W.R.C., "Measurements of Overbank Flow in a Compound River Channel", Proc. of the Inst. of Civil Eng., Part 2, 91. December, 645-657, 1991.
11. Cassells, J.B.C , Lambert, M.F. and Myers, R.W.C., "Discharge Prediction in Straight, Mobile Bed Compound Channels", Proc. of the Inst. of Civil Eng. Water & Marit. Eng., Vol 148, 177-188, 2001.
12. Knight, D.A. and Brown. F.A., "Resistance Studies of Overbank Flow in Rivers with Sediment Using the Flood Channel Facility", J. of Hyd. Res., Vol 39, 283-301, 2001.
13. Lyness, J.F., Myers, W.R.C., Cassells, J.B.C. and O'Sullivan, J.J., "The Influence of Platform on Flow Resistance in Mobile Bed Compound Channels", Proceedings of the Institution of Civil Engineers Water and Maritime Engineering, Vol 148, 5-14, 2001.
14. Bousmar, D. and Zech, Y., "Momentum Transfer for Practical Flow Computation in Compound Channels" , J. of Hyd. ASCE, Vol 125, 696-706, 1999.
15. Lambert, M.F. and Myers. W.R., "Estimating the Discharge Capacity in Straight Compound Channels", Proc. Instn. Civ. Engrs. Wat., Mar. & Energy, Vol 130, 84-94, 1998.
16. Myers, W.R.C.. Lyness, J.F. and Cassella, J., "Influence of Boundary Roughness on Velocity and Discharge in Compound River Channels", Journal of Hydraulic Research, Vol 39, 311-319, 2001.
17. Ali, N. A. "A Contribution to sediment transportation with reference to hydraulic resistance", M. Sc. Thesis, Civil Eng. Dept., Assiut Univ., 1978.
18. Chatlerjee, S. S., and ghosh, S. N., "Submerged horizontal jet over erodible bed", J. of Hyd. Div., ASCE, Vol. 106, 1980.
19. Yang, C. T., "Sediment Transport: Theory and Practice" McGraw-Hill Book Co., NewYork, 1996.
20. Patra K. C. and Kar S. K., "flow interaction of meandering river with floodplains", J. of Hyd. Eng., Vol. 126, 593-604, 2000.

خصائص السريان بالقنوات المكشوفة المركبة

تناولت الكثير من الأبحاث دراسة خصائص السريان في القنوات المركبة المكشوفة سواء كانت هذه القنوات مستطيلة أو على شكل شبة منحرف ولكن لم يتم دراسة خصائص السريان في القنوات المكشوفة ذات القطاعات المركبة إلا في أبحاث قليلة و حيث أننا نتعرض لهذه الحالة في وجود الجزر المغمورة في المجارى المائية حيث يترتب عليها وجود مقاطع ذات أعماق مختلفة. لذا فان هذا البحث يتناول دراسة خصائص السريان بالقنوات المكشوفة المركبة من معادلات تصرف – سرعات – سواء كانت طولية أو عرضية و رأسية وكذلك القوى المائية الناتجة عن تركيب القطاع. في محاولة للوصول إلى طريقة لتقسيم القطاع المركب إلى مجموعة من القطاعات البسيطة التي يمكن تطبيق معادلات السريان عليها للحصول على تقدير دقيق لمعدل التصرف المار بالقنوات المكشوفة المركبة. كما تمت دراسة التيارات المائية العرضية للاستفادة منها في التعرف على اتجاه هجرة وانتشار الملوثات بالقنوات المركبة.

أجريت التجارب على قناة مكشوفة ذات قطاع مستطيل. تم تشكيل قطاع مركب ذو مجرى ضحل من جانب واحد من القناة الرئيسية وذلك باستخدام كتلة خشبية ذات عرض ثابت وذلك لتثبيت عرض القناة الرئيسية. تم تغيير إرتفاع الكتلة الخشبية مرتين ليصبح ١٥ سم و ٩ سم كما تم أيضا تغيير ميل قاع القناة ليأخذ القيم من ٠.٠٠٢٤٣ إلى ٠.٠٠٣٧ وكذلك تم تغيير رقم فرويد ليأخذ القيم من ٠.١٢ إلى ٠.٧٣ وكانت نسبة عمق مياه المجرى الضحل إلى عمق مياه القناة الرئيسية تتراوح ما بين ٠.٢٢ و ٠.٧٨ ثم تغيير خشونة القاع مرتين. وقد كان من أهم النتائج المستخلصة من هذه الدراسة إيجاد تقسيم للسريان على مستوى أفقى يعطو منسوب قاع المجرى الضحل بمقدار (٠.٤٠ عمق المياه عند المجرى الضحل) يتم على أساسه الحساب الدقيق لمعدل التصرف فى القطاعات المركبة باستخدام معادلات السريان فى القنوات المكشوفة. ومن تحليل خصائص السريان بالقنوات المكشوفة المركبة تم استنتاج ان التيارات المائية تحدث من المجرى الضحل الى المجرى العميق عندما يكون عمق المياه صغير بالمجرى الضحل وهذا قد يؤثر على هجرة الملوثات التى يمكن القاؤها بجانب المجرى.

$k - \varepsilon$ (turbulent kinetic energy and dissipation rate) model for the