

CONTRIBUTION OF NON-STRUCTURAL BRICK WALLS DISTRIBUTIONS ON STRUCTURES SEISMIC RESPONSES

Hamdy H. A. Abd el-Rahim^{1,*} and Ahmed Abd El-Raheem Farghaly²

^{1,*} Associate Professor, civil eng department, Faculty of Engineering, Assiut University

² Lecturer, Faculty of Industrial Education, Sohag University

Received 5 January 2013; accepted 10 February 2013

ABSTRACT

Using of masonry infill as partitions, in flat slab frame buildings is a common practice in many parts of the worlds. The infill is, generally, not considered in the design and the buildings are designed as bare frames. More of fundamental information in the effect of masomary infill on the seismic performance of RC building frames is in great demand for structural engineers. Therefore the main aim of this research is to evaluate the seismic performance of such buildings without (bare frame) and with various systems of the masonary infill. For this purpose, thirteen three dimensional models are chosen and analyzed by SAP2000 program. Nonlinear time history analysis recommended by Egyptian code for seismic load of building structures was used (ECOL 201, 2008) [31]. In this study the stress strain relation model proposed by Crisafulli [7] for the hysteric behaviour of masonry subjected to cyclic loading is used. The results show that the nonstructural masonary infill can impart significant increase global strength and stiffness of such building frames and can enhance the seismic behaviour of flat slab frame building to large extent depending on infill wall system. As a result great deal of inspirit has been obtained on seismic response of such flat slab buildings which enable the structural engineer to determine the optimum position of infill wall between the columns.

Keywords: Earthquake, Non-Structural brick walls, bare frame, Masonry infill, reinforced concrete frame, Non-linear modeling, Time history analysis.

1. Introduction

The infill masonry is seldom included in numerical analysis of structural system, because masonry panels are generally considered as structural elements of secondary importance, which introduce some unwanted analytical complexities without having pronounced effect on the structural performance. However, the significant effects of the infilled masonry on the structural responses of frames have been realized by many researchers (Harpal, Paul and Sastry, 1998[16], Hong, et al. 2002[19], Sahota and Riddington, 2001[28], Nollet and Smith, 1998[23])

It yields that the presence of nonstructural masonry infill can affect the seismic behavior of framed building to large extent.

These effects are generally positive: masonry infill can dramatically increase global stiffness and strength of the structure. On the other hand, potentially negative effects may occur such as torsional effects induced by in plan-irregularities, soft-storey effects induced irregularities in elevation and short-column effects due to openings. The objective of this

* Corresponding author.

Email address: hamdy010@yahoo.com

study is to investigate the response of reinforced concrete structure subjected to ground motion to assess structural damage by focusing on the effects of infill masonry on the structural performance. In this study, El Centro earthquake records are applied to simulate ground motion.

There is strong evidence that masonry infill enhance the lateral strength of framed building structures under severe earthquake loads and have been successfully used to strengthen the existing moment-resisting frames in some countries (Amrhein et al. 1985)[1].

However, there is a common misconception that masonry infill in reinforced concrete (R/C) or structural steel frames can only enhance their lateral load performance and must therefore always be beneficial to the earthquake resistance of the structure. As a matter of fact, there are numerous cases of seismic damage that can be attributed to modification of the dynamic response parameters of the basic structural frame by so-called nonstructural masonry infill or even partitions. The addition of masonry infill panels to an original bare moment resisting frame increases the lateral stiffness of the structure, thus shifting the natural time period on the earthquake response spectrum in the direction of the higher seismic base and storey shears, and attracting earthquake forces to parts of structures not designed to resist them. Furthermore, if the structure is designed to act as a moment resisting frame with a ductile response to the design level earthquakes, neglecting the contribution of infill, the stiffening effect of the infill may increase the column shears resulting in the development of plastic hinges at the top of the columns that are in contact with the infill corners (Paulay and Priestley, 1992)[26].

One of the lessons learnt from past experiences in earthquakes is that abrupt changes in stiffness along the height of a building due to irregular distribution of masonry infill panels over the elevation of the building frame can unfavourably and sometimes catastrophically affect the seismic performance of the frame. The complexity in predicting the seismic performance of masonry infilled frames with irregular distribution of masonry infill panels further underscores the importance of modelling and analysing the structural contribution of the masonry infill panels to the seismic response of the unfilled frame. Despite rather intense research (Dhanasekar and Page, 1986) [8], (Chrystomou et al., 1992) [6] in theoretical modeling of masonry infilled frames during the past few decades, displacement-based nonlinear analyses of masonry infilled frames with explicit consideration of infill panels as structural elements is far from common practice, mostly due to lack of realistic and computationally efficient models for representing the nonlinear hysteretic response of masonry infill panels subjected to cyclic load reversals. The displacements are of particular interest from the viewpoint of performance-based design, the emerging paradigm for the next generation of international standard codes of practice for earthquake-resistant design.

The literature review (Fiorato et al., 1970)[11], (Chrystomou et al., 1992) [6] indicates that there is need for a systematic study for the assessment and quantification of the effect

of vertical distribution of masonry infill panels on the seismic performance and possible seismic damage of practical masonry infilled R/C framed building structures under the influence of design level as well as maximum credible earthquakes in India using nonlinear displacement-based analysis procedures. However, the theoretical evaluation of seismic damage in practical masonry infilled frame structures presents a complex problem, since a realistic assessment of structural damage due to earthquake ground motion, strictly speaking, requires a nonlinear dynamic analysis of the entire structure taking into account the hysteretic response of various structural components. This article presents an analytical investigation of the effect of the layout of masonry infill panels over the elevation of masonry infilled R/C frames on the seismic performance and potential seismic damage of the frame under strong ground motions using rational analytical methods such as nonlinear dynamic time-history analysis and nonlinear static push-over analysis based on realistic and efficient computational models.

The top 10 architectural design requirements related to confined masonry buildings are:

- 1) Building plan should be regular.
- 2) The building should not be excessively long relative to its width; ideally, the length to-width ratio should not exceed 4.0.
- 3) The walls should be built in a symmetrical manner.
- 4) The walls should be continued up the building height.
- 5) Openings (doors and windows) should be placed in the same position up the building height.
- 6) Tie-beams should be placed at every floor level in a vertical spacing not to exceed 3m.
- 7) Tie-columns should be placed at a maximum spacing of 4 m.
- 8) At least two confined walls should be provided in each major direction.
- 9) Wall density of at least 2 % is required to ensure good earthquake performance of confined masonry construction.
- 10) Confined masonry is suitable for low- to medium-rise building construction (one- to four-storey high), depending on the seismic zone.

The first approach in modeling a masonry panel is to consider the masonry as a homogeneous material including the masonry units and the mortar together as a continuum (Fig. 1a). The interfaces are actually the weakest link in a masonry assemblage and cannot be modeled by smeared crack patterns, since in this case some individual cracks may control the behavior of the whole panel (Lourenco 1996 [21]; Shing and Mehrabi 2002[29]).

2. Properties of the composite material

The compressive strength of masonry in the direction normal to the bed joints has been traditionally regarded as the sole relevant structural material property. The RILEM test (Wesche, and Ilantzis 1982) [30] seems to return the true uniaxial compressive strength of masonry. Since the pioneering work of Hilsdorf [18] it has been accepted by the masonry

community that the difference in elastic properties of the unit and mortar is the precursor of failure.

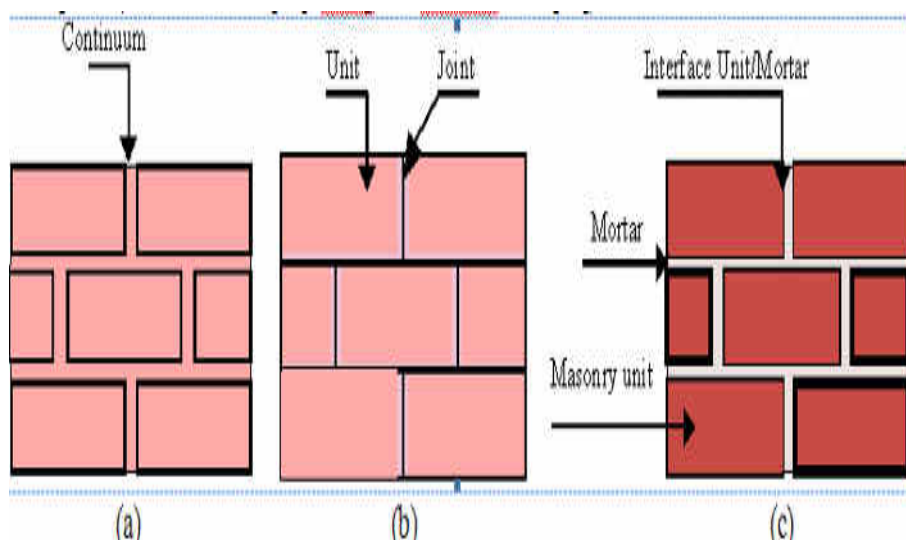
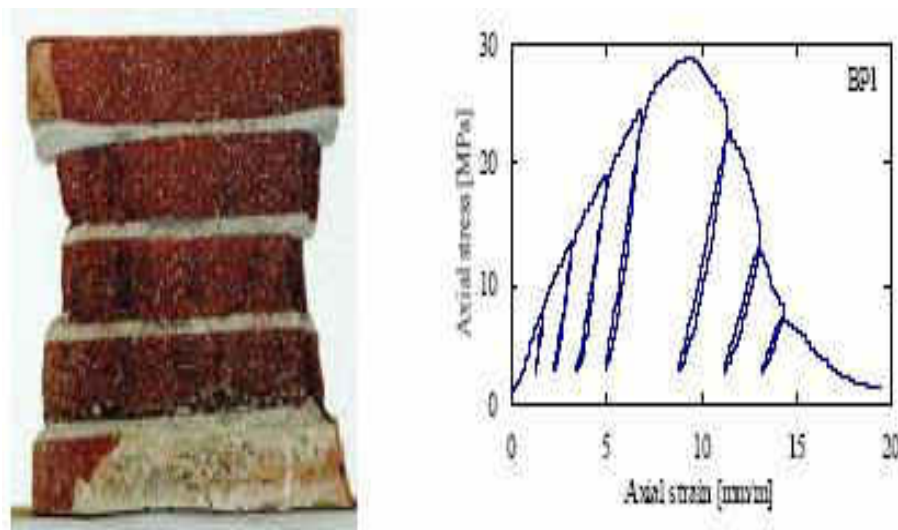

Fig. 1. Different masonry modeling strategies recognized by Lourenco (1996) [21]

Uniaxial compression tests in the direction parallel to the bed joints have received substantially less attention from the masonry community. For tensile loading perpendicular to the bed joints, masonry strength can be generally equated to the tensile bond strength between the joint and the unit, or the tensile strength of the unit, whichever is the lowest. For tensile loading parallel to the bed joints, a sophisticated direct tension test program was set-up (Backes, 1985) [3], where two different types of failure have been obtained: stepped cracks through head and bed joints or cracks running almost vertically through the units and head joints. In all cases, the strength degradation has been fully characterized. The influence of the biaxial stress state has been investigated up to peak stress to provide a biaxial strength envelope, which cannot be described solely in terms of principal stresses because masonry is an anisotropic material. Basically, two different test set-ups have been utilized, uniaxial compression oriented at a given angle with respect to the bed joints (Hamid and Drysdale 1981) [15] and true biaxial loading at a given angle with respect to the bed joints (Page 1981) [25], (Ganz and Thürlimann 1982) [13]. Next, some results for masonry specimens under uni-axial compression (Oliveira, 2002) [24] are briefly reviewed. A series of unloading-reloading cycles were performed, particularly in the post-peak region, to acquire data about stiffness degradation and energy dissipation. The typical failure and stress-strain diagrams are illustrated in Fig. 2. Apart from the initial adjustment between the prism and the machine platens, stress-strain curves exhibited a pre-peak bilinear behavior, which has been reported by other authors. An initial linear branch was followed by another branch up to near the peak, with lower stiffness and greater

development. The response clearly indicates an important and monotonic decrease in Young's modulus in the post-peak regime, associated with damage growth in the material.



(a) Typical failure of masonry specimen b) Typical stress-strain diagram.

Fig. 2. Aspects related to the cyclic behavior of masonry specimens under uni-axial compression ((Oliveira, 2002) [24])

2.1. Cyclic behavior of infill panel

In this section, the model proposed by Crisafulli (1997) [7] for the hysteric behavior of masonry subjected to cyclic loading is described. The model is capable of taking into account the non-linear response of masonry in compression. As the model allows taking into account the variation of struts cross section as a function of the axial deformation experienced by element, it is possible to consider the loss of stiffness due to shortening of the contact length between frame and panel as the lateral load increases. Stress Strain relation for the hysteric model proposed is shown Fig. 3.

A reinforced concrete structure was strengthened with solid brick infill walls. The added walls were effective in increasing base shear strength (by approximately 100%) and lateral stiffness (by approximately 500%). (Pujol and Fick, 2010)[27]

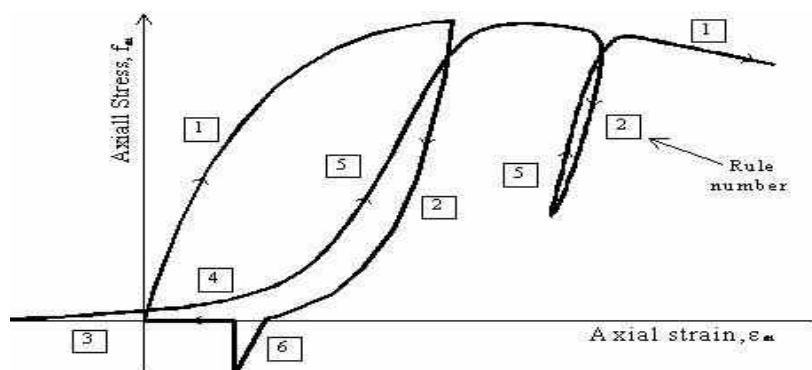

Fig. 3. Used general characteristics for cyclic axial behavior of masonry (Crisafulli 1997) [7]

During earthquake, the infill itself is subjected to in-plane, as well as, out-of-plane forces. In in-plane action, it may fail in any of the last three modes, described above. In case of slender infill, the failure may also occur due to buckling. In out-of-plane action, the infill fails in bending tension in the case of panels with high h/t ratio, while an arching mechanism is developed, in case of panels with relatively low h/t ratio (FEMA 356,2000) [10]. Generally, the infill first crack due to in-plane action and then fail, with or without arching action, due to out-of-plane forces. The overall phenomenon is quite complex to be handled in totality. In the present study, the in-plane strength of infill and their effect on the seismic behaviour of RC frame buildings have been studied.

A bare frame (without infill) must be able to resist the earthquake effects. Infill walls must be uniformly distributed in the building. Masonry infill should not be discontinued at any intermediate story or the ground story level; this would have an undesirable effect on the load path.

When ductile RC frames are designed to withstand large displacements without collapse, masonry infill should be isolated from the frame by a sufficient gap. In this manner, masonry infill walls do not affect the frame performance and frame displacements are not restrained. Another advantage of the isolated masonry infill is that the walls remain undamaged, thereby reducing post-earthquake repair costs. From the point of view of controlling weather conditions inside the building, the gaps need to be sealed with an elastic material; these provisions may be expensive and require good construction details to be executed with precision. Overall, based on the poor earthquake performance of non-ductile RC frame buildings and also load-bearing masonry buildings, confined masonry construction is emerging as a better alternative for low-rise buildings in developing countries (Brzev 2007) [5]. This type of construction is much easier to build than ductile frames with isolated infills.

2.2. In-plane behavior of infill-frames

The masonry infill changes the mass, damping, stiffness and strength properties of the whole integrated structure. Some design codes acknowledge the difference between a bare frame and an infill-frame; however these provide recommendations mainly on the global behaviour of the structure such as the natural period or the reduction factor (Hemant et al. 2006)[17].

FEMA 306[9] identifies the difficulty in considering the behaviour of infill-frame to the following:

- a) Discontinuity of the infill resulting in a soft storey;
- b) Various cracking patterns and concentration of forces in structural components;
- c) Large variation in construction practice in different regions;
- d) Changes in materials over time: brick, stone, concrete masonry or concrete panels, reinforced/unreinforced masonry, grouted/un-grouted masonry, steel and concrete frames.

However it is important to realize that there can be some undesirable effects from the structural interaction between the infill and frame such as:

- a) Brittle shear failure (either in the frame members or the infill);
- b) Altering in-plane stiffness distribution in plan and elevation due to the provision of an irregular arrangement of infill panels leading to a soft-storey and/or a magnified torsional effect;
- c) Infill collapse which can cause loss of life and an increase in the number of casualties;
- d) Short-column effect, especially in the case of mid-height infill or infill with an opening (partial infill) leading to unexpected ductility demand in columns. The assumption that the infill will fail under pure in-plane loads, whereas under earthquake loads they may collapse as the result of out-of-plane loads before they reach to their ultimate in-plane capacity.

2.3. Out-of-plane behavior of infill-frames

The out-of-plane behavior of infill-frames has been investigated since the 1950s. As reported by Shing and Mehrabi (2002) [29], many studies (Angel 1994[2], Mander et al. 1993[22]; Bashandy et al. 1995[4]; and Flanagan 1999[12]) on out-of-plane behavior of infill-frames indicate that infill panels restrained by frames can develop significant out-of-plane resistance as a result of arching effect. The out-of-plane strength of a masonry infill is mainly dependent on its slenderness. If an “x” pattern of cracks develops under both in-plane and out-of-plane loading, this implies that there may be some substantial deterioration in either in or out-of plane strength under the loading in the opposite direction (Angel 1994)[2]. It is shown by Angel (1994)[2] that the out-of-plane strength deterioration may reach as much as 50% for infill panels with high slenderness ratio where they have already been cracked under lateral in-plane loading. Based on the results of tests conducted by (Angel, 1994)[2], the following behaviour can be expected due to different values of slenderness ratio:

- a) Crushing along the edges for low h_m/t (where h_m and t are the height and thickness of the infill panel, respectively);
- b) Snap-through (small effect of arching) for high h_m/t i.e. approximately between 20 and 30 (this limit depends on the crushing strain of the masonry which usually varies between 0.002 and 0.005).

Regarding the out-of-plane behaviour of masonry (bare) walls, it has been shown that they exhibit substantial out-of-plane displacement capacity and hence more ductile behaviour than is conventionally accepted (Griffith *et al.* 2007) [14]. A comprehensive study on the damping of masonry walls in out-of-plane (on-way) flexure can also be found in Lam *et al.* (2003) [20].

Four types of failure modes have been identified (Pauley and Priestley, 1992) [26] in case of infill frame buildings: (1) Tension failure of the tension side column resulting from the applied overturning moments in infill frames with high aspect ratio, (2) Sliding shear failure of the masonry along horizontal mortar bed joint causing shear hinges in the columns due to short column effect, (3) Compression failure of the diagonal strut, and (4) Diagonal tensile cracking of the panel (see Fig. 4a, 4b and 4c).

2. Model description

To observe the effect of infill on the global behavior of flat slab frame buildings, a 12 stories building, with identical plan, as shown in Fig. 5, have been considered. The overall plan dimensions are 10.0m x 10.0m, measured from the centre line of the columns. The height of the ground floor is 3.0m and inters storey heights are 3m. A flat slab of 20cm thickness has been considered for all stories. The thickness of the exterior and interior infill has been considered as 12cm and 25cm. However, the effect of opening on stiffness and strength has been ignored.

Method of connecting walls to RC flat slab frame is the interface between the masonry wall and the concrete tie-column needs to remain smooth for appearance's sake, steel dowels should be provided in a mortar bed joints to ensure interaction between the masonry and the concrete during an earthquake (see Fig.6). It is assumed that, other than dowels, horizontal reinforcement is not provided in the walls.

Figure 7 shows the different cases (13 cases) of study the first case bare flat slab frame building, all wall cases in the 12 stories at the centre line between columns, then a case of no walls at ground story and repeat this case in second story till the tenth story to study the effect of absence of infill in each story on the base shear, drift of each story and base normal force in columns.

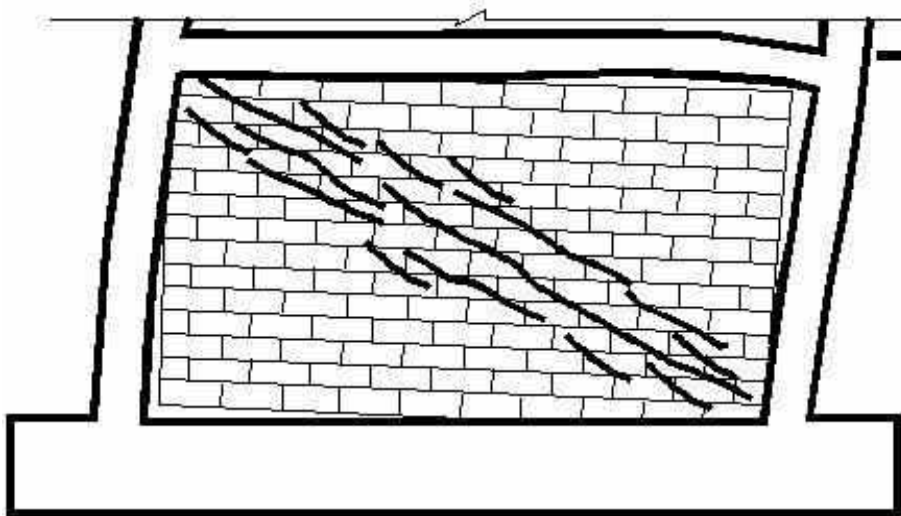

a) Damage or failure of the masonry panel:

- Shear friction failure
- Diagonal tension failure
- Compressive failure

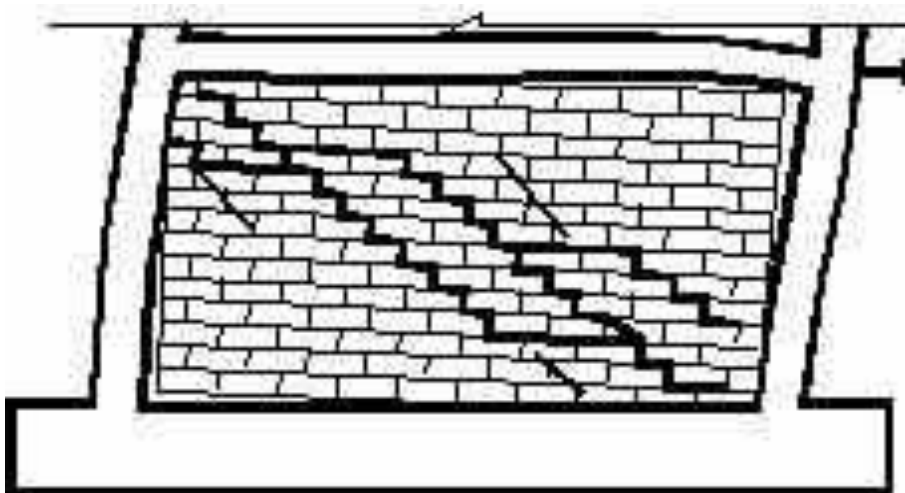

b) Damage or failure of the masonry panel:

- Shear friction failure
- Diagonal tension failure
- Compressive failure

Fig. 4. Types of Failure Modes

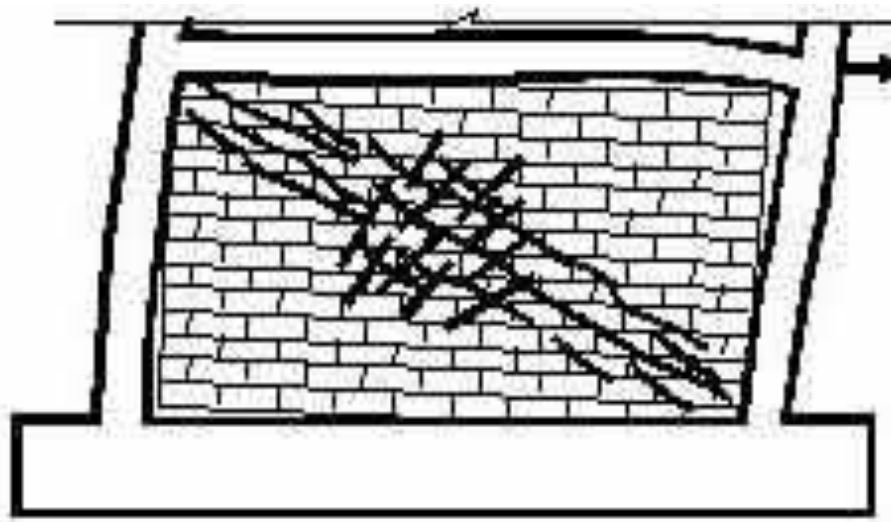

c) Damage or failure of the masonry panel:

- Shear friction failure
- Diagonal tension failure
- Compressive failure:
 1. Failure of the diagonal strut
 2. Crushing of the corners.

Cont. Fig. 4. Types of Failure Modes (Pauley and Priestley, 1992) [26]

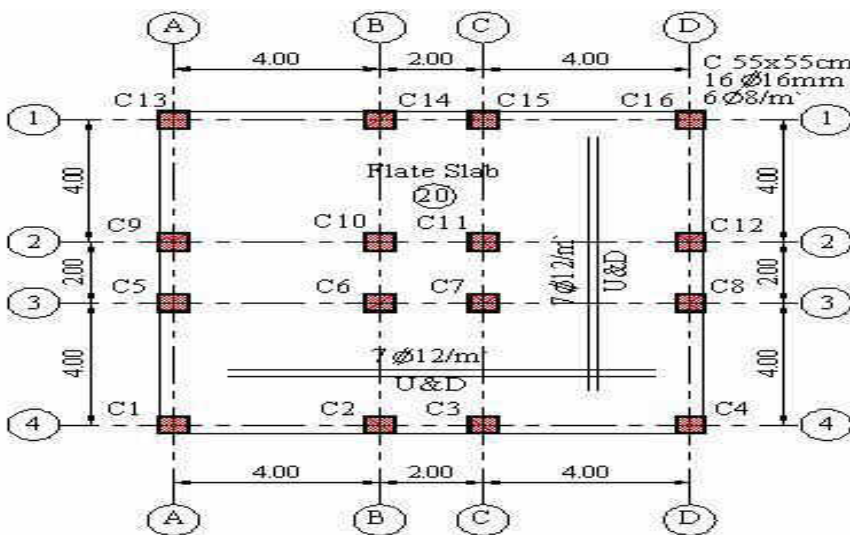

Figure 5: Specification and plan of identical floors of the models

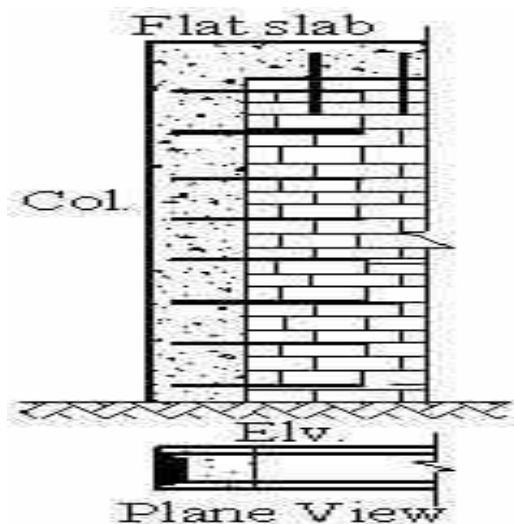

Fig. 6. Horizontal dowels at the wall-to-column interface (Note that the tie-column reinforcement is not shown)

Table 1 describes the 13 cases of study with its abridgment.

Table 1
Description of study cases models

No.	Symbol	Description	No.	Symbol	Description
1	Bare	Flat slab frame without infill brick wall	8	5th	Flat slab frame with infill brick wall except fifth floor
2	All	Flat slab frame with infill brick walls at each floor	9	6th	Flat slab frame with infill brick wall except sixth floor
3	G	Flat slab frame with infill brick wall except ground floor	10	7th	Flat slab frame with infill brick wall except seventh floor
4	1st	Flat slab frame with infill brick wall except first floor	11	8th	Flat slab frame with infill brick wall except eighth floor
5	2nd	Flat slab frame with infill brick wall except second floor	12	9th	Flat slab frame with infill brick wall except ninth floor
6	3rd	Flat slab frame with infill brick wall except third floor	13	10th	Flat slab frame with infill brick wall except tenth floor
7	4th	Flat slab frame with infill brick wall except fourth floor			

In bare flat slab frame building, the live load distributed on the slab equivalent to the weight of the absence brick walls which the designer does at analysing such kind of building. By using the requirements of the flat slab building no undertake into place of the brick walls, so that the full walls will be constructed between all columns in all parts.

SAP 2000 (v 8.1.2) was utilized for the heterogeneous modelling study of the masonry systems using solid and shell elements. So, SAP 2000 (v 8.1.2) will be used in this study.

2.1. Input loadings

The unit weight of walls 1.8t/m^3 , Live load intensity on the floors and roof has been taken 1300kg/m^2 and 1066kg/m^2 , for infill walls thickness 25cm and 12cm respectively (unite weight = 1.8 t/m^3) in the case of bare flat slab frame building, but in the all 12 other cases live lode will be 200kg/m^2 and cover 150kg/m^2 in all stories. A lightweight brick was used as alternative of red brick in the flat slab frame building of unit weight 600kg/m^3 .

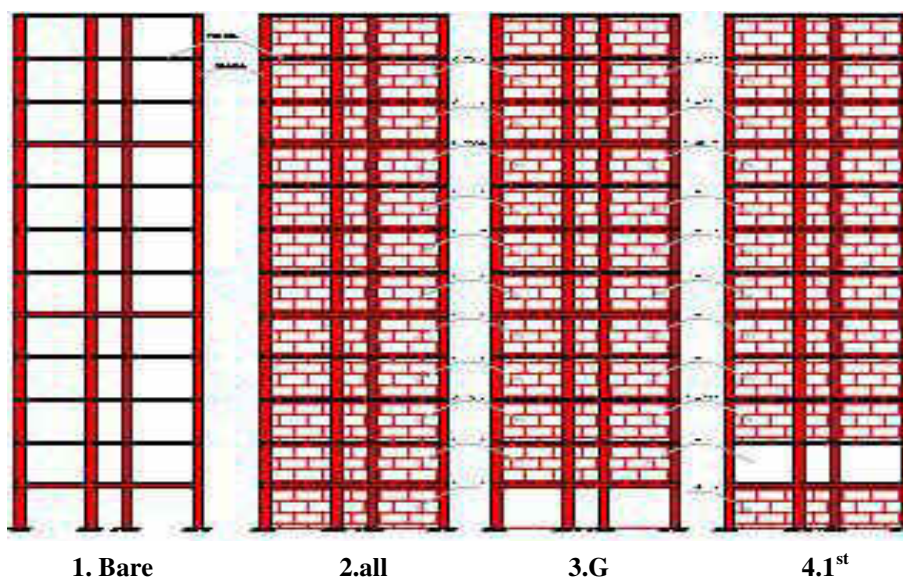

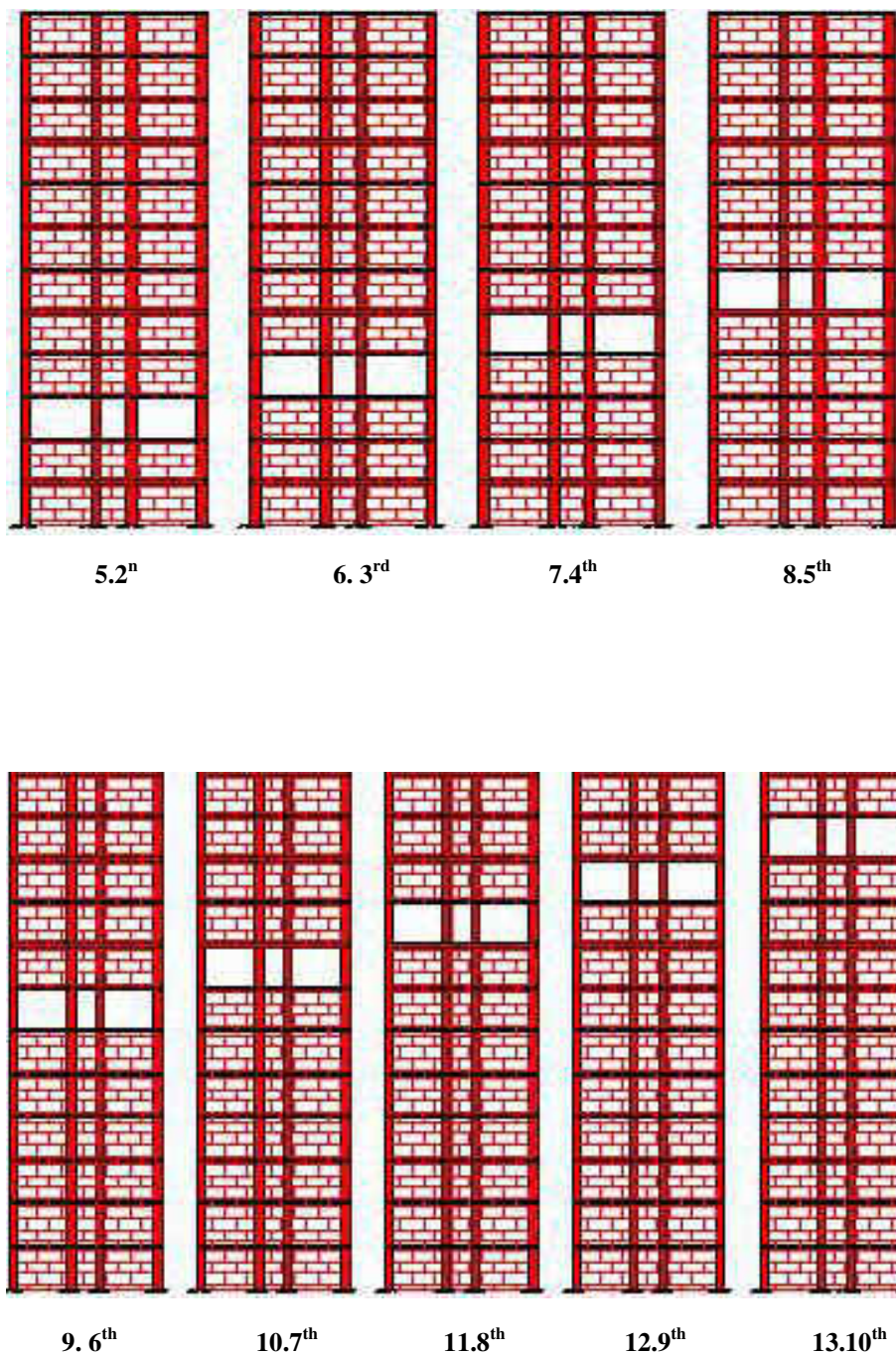

Fig . 7. Different study cases of infill arrangement in different stories

A time history analysis was carried out using El Centro earthquake and ten models are excited by three orthogonal components of seismic motion which has maximum acceleration 0.5g (Fig. 8) (the earthquake affects on two directions X, and Y of the tested model).

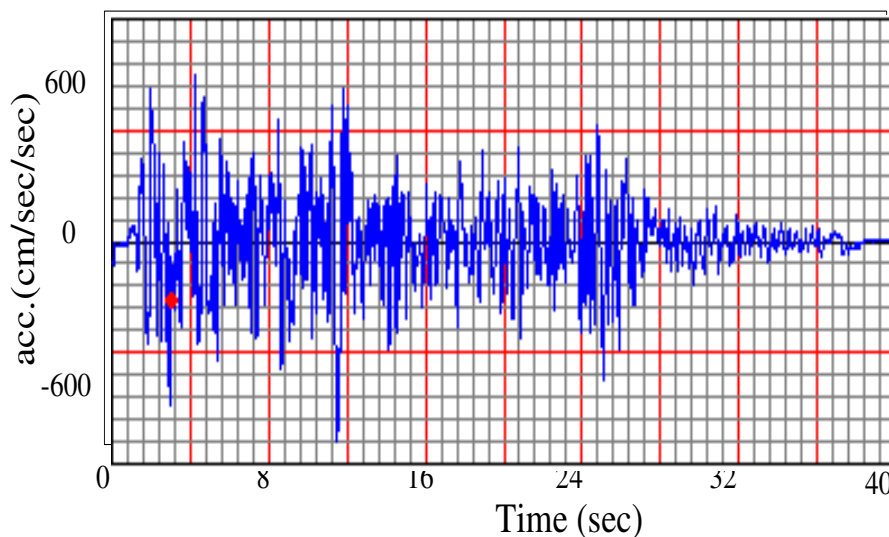

Fig. 8. El Centrio Model Vibration

3. Results and discussion

To study the performance of brick walls in flat slab frame building subjected to earthquake , 13 models were studied and the bare flat slab frame (without any infill brick walls) chose as a reference case, which will compare the other cases.

Figure (9) displays the displacement values for each storey in the various study cases. Fig. (9-a) shows the displacement of each storey in the cases bare (as reference case), all, G, 1st, 2nd, 3rd, 4th, 5th, 6th, 7th, 8th, 9th, 10th with 12 cm wall brick thickness. Fig (9-b) shows the displacement of each storey in the cases bare (as reference case), all, G, 1st, 2nd, 3rd, 4th, 5th, 6th, 7th, 8th, 9th, 10th with 25 cm wall brick thickness. The displacement of each floor in bare case is greater than the displacement of each floor in case of all by nearly 6 times for each case of study from 1st to 10th. The ratio between displacement of bare case and the other cases equal to nearly 20 in first floor of the model in each case study from 1st to 10th.

The displacement as shown in figures increase by nearly 2 times after the floor which is absence of brick in every case studied from 1st to 10th cases, but in case all displacements equals 0.2 times displacement of bare case, and displacement in G case equals to 0.33 times of displacement in the bare case for each floor (from first to twelve floors).

Displacement in case of 12cm brick wall thickness is less than 25cm brick wall thickness by nearly 1.2 times in all cases.

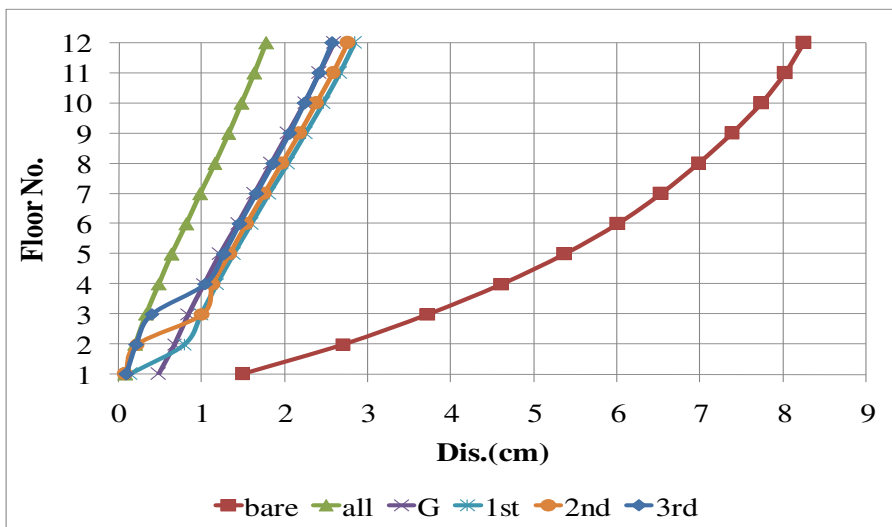

i) Displacement of stories in cases bare, all G, 1st, 2nd, 3rd

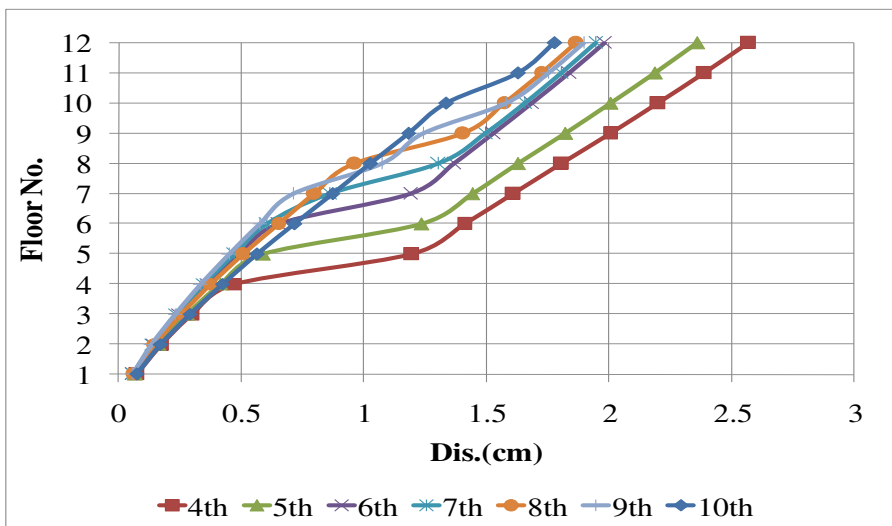

ii) Displacement of stories in cases 4th, 5th, 6th, 7th, 8th, 9th, 10th

a) 12cm brick thickness

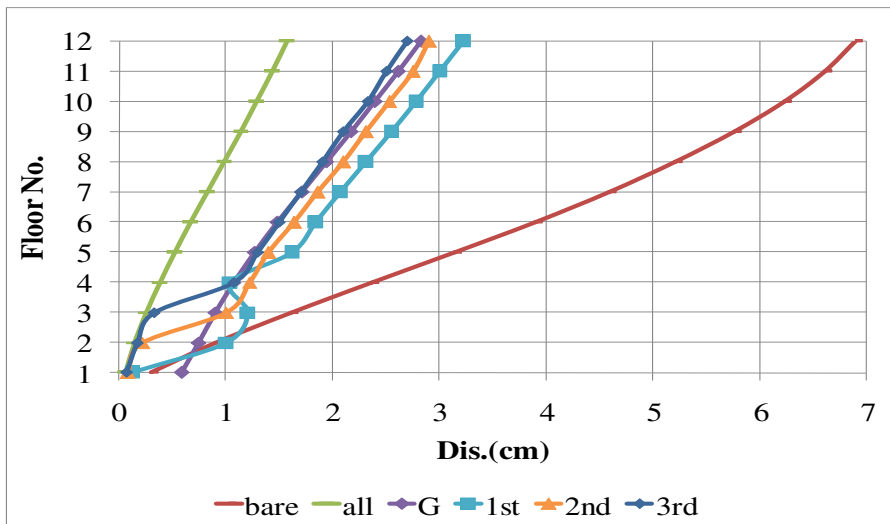

i) Displacement of stories in cases bare, all G, 1st, 2nd, 3rd

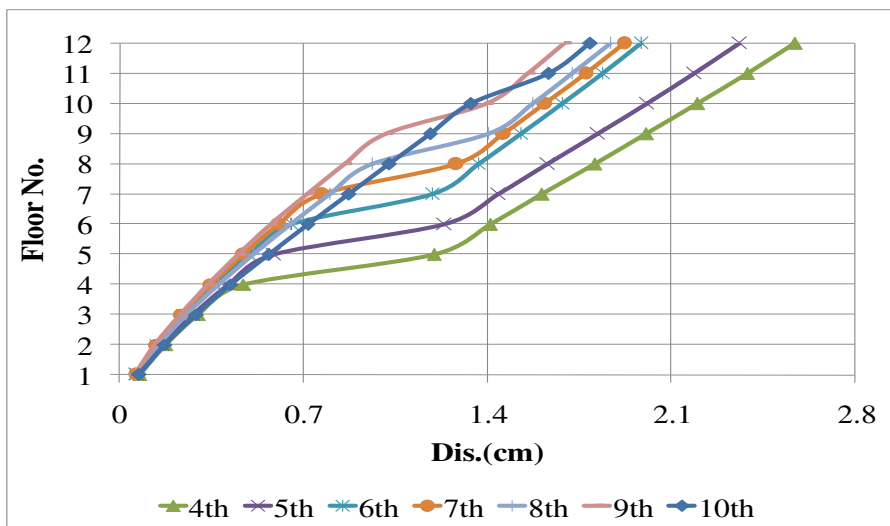

ii) displacement of stories in cases 4th, 5th, 6th, 7th, 8th, 9th, 10th
 b) 25cm brick thickness

Fig. 9. Displacements of storey with respect to height in each study case

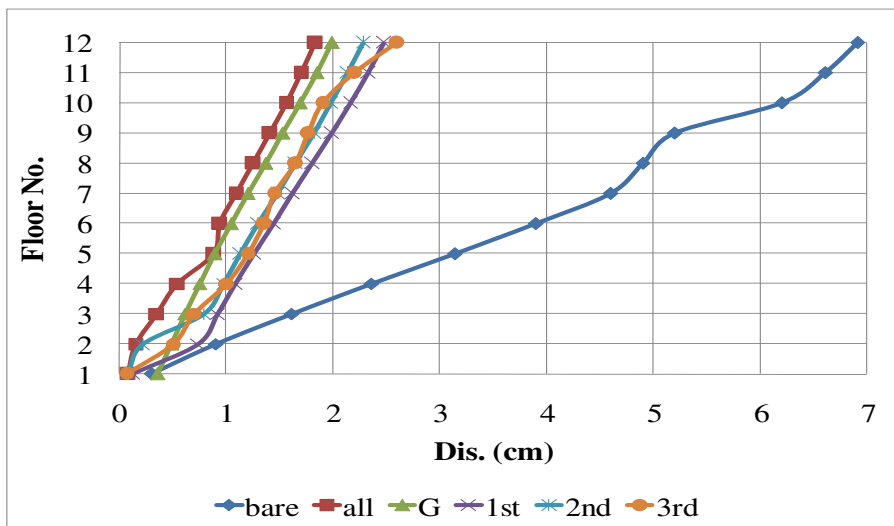

i) Displacement of stories in cases bare, all G, 1st, 2nd, 3rd

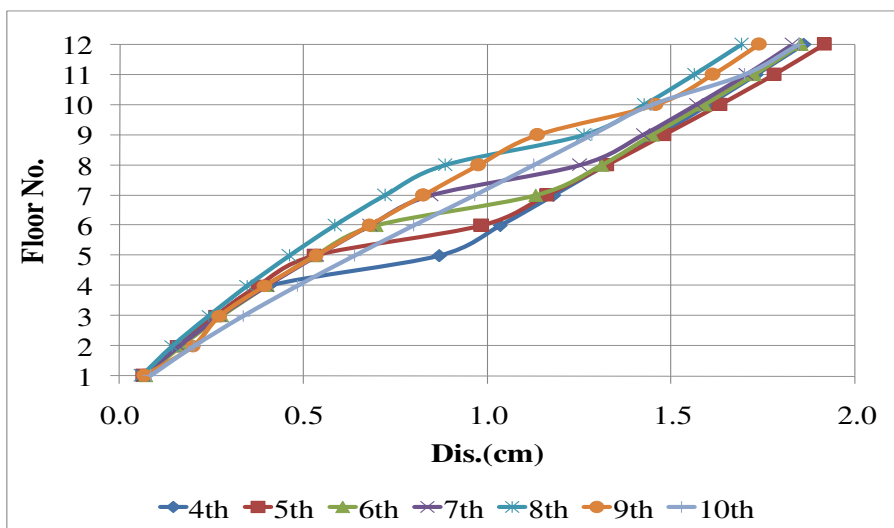

ii) Displacement of stories in cases 4th, 5th, 6th, 7th, 8th, 9th, 10th
 c) 20cm light brick thickness

Cont. Fig. 9. Displacements of storey with respect to height in each study case

Figure 10 shows the base shear in all columns for various cases of brick wall arrangements, brick wall thickness 12cm and 25cm, and lightweight brick wall.

Figure (10-a) illustrates the base shear of ground floor columns of 12cm brick wall thickness. In all ground columns in all study cases the ratio between base shear G and 1st cases are equal to nearly 0.33 and 0.25 respectively.

Figure (10-b) illustrates the base shear of ground floor columns of 25cm brick wall thickness. In all ground columns in cases bare, all, 2nd, 3rd, 4th, 5th, 6th, 7th, 8th, 9th, and 10th base shear are nearly equal in each case. The ratio of base shear for columns 1 to 4, 6, 8, 13, 14, 15, and 16 in bare case equal to nearly 0.20 the base shear in cases G and 1st. The ratio of base shear in all ground columns in G and 1st cases and all other cases equals to nearly 0.25 and 0.2 respectively.

Figure (10-c) illustrates the base shear of ground floor columns of 20cm lightweight brick wall thickness. In all ground columns in all study cases the ratio of base shear G and 1st cases equals to nearly 0.33 and 0.25 respectively.

For 25cm brick wall thickness shear force increase in columns than 12cm brick wall thickness by nearly 1.5 times in G case (absence of brick walls in ground floor).

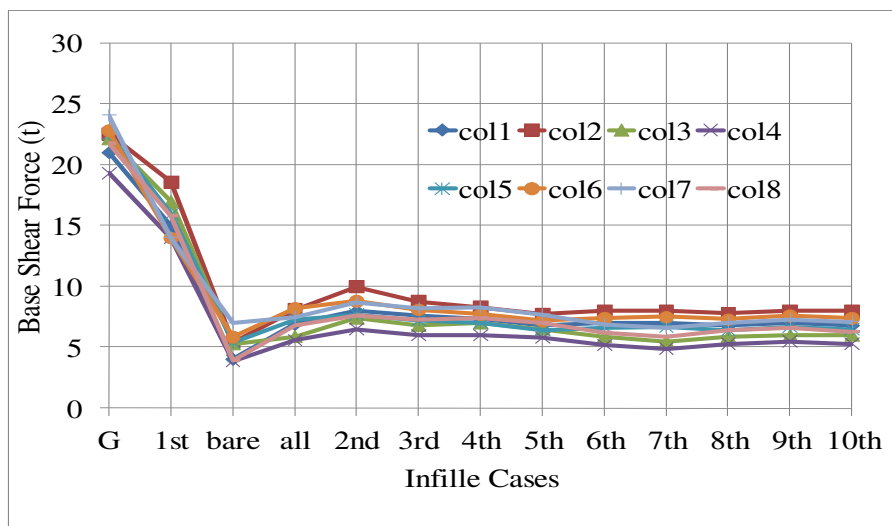

i) Base shear for columns No.1 to 8

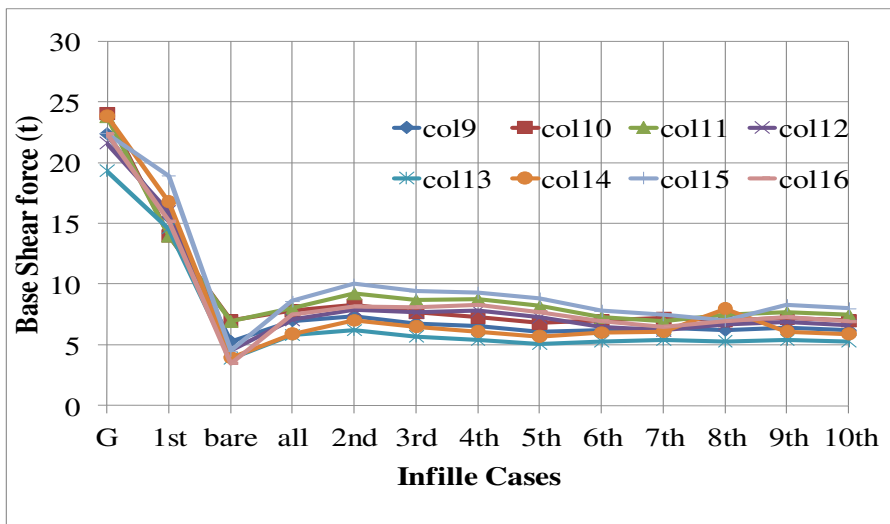

ii) Base shear for columns No. 9 to 16
 a) 12cm thickness brick walls

Fig. 10. Base Shear in each study case

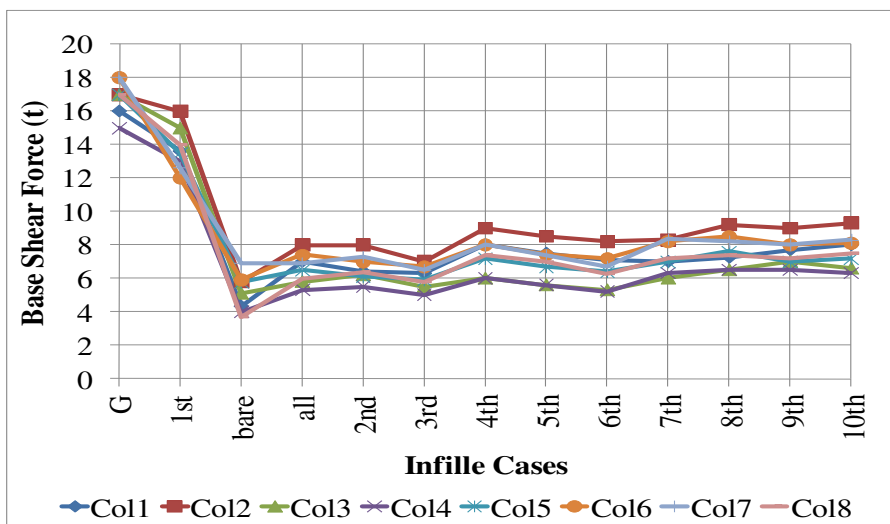

i) Base shear for columns No. 1 to 8

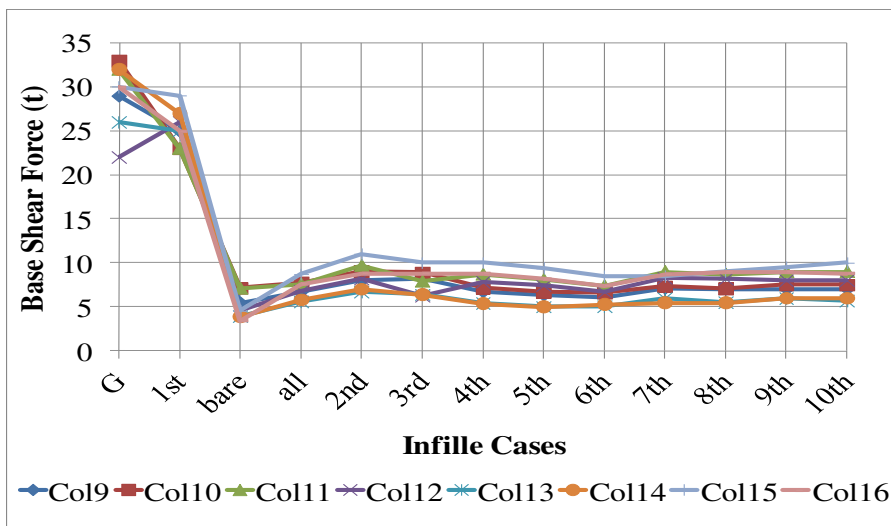

ii) Base shear for columns No. 9 to 16
 b) 25cm thickness brick walls

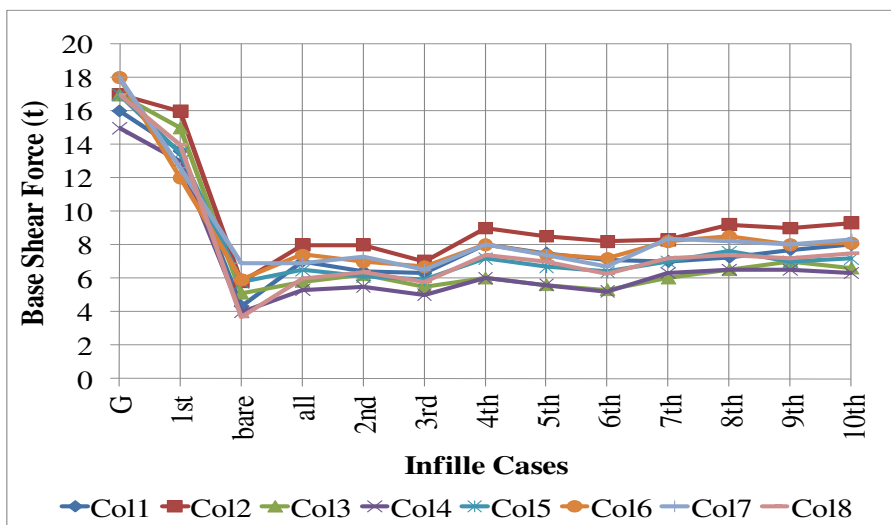

i) Base shear for columns No. 1 to 8

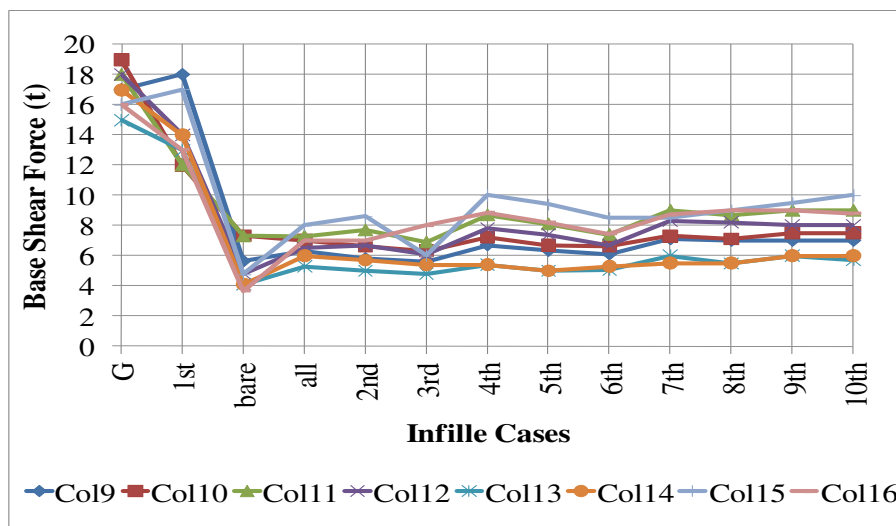

ii) Base shear for columns No. 9 to 16
c) 20cm thickness lightweight brick walls

Cont. Fig. 10. Base Shear in each study case

Figure 11 shows normal forces in ground columns in various cases of brick wall arrangements and thickness.

Figure (11-a) and Fig.(11-b) show the normal forces on the ground floor columns in various cases of brick wall arrangements and different brick wall thickness. For columns 10,11,13,7,6 and 4 are the least affected columns in values of normal force between different case of brick wall arrangements and all other columns in the ratio between the normal force in all study cases and bare case equals to nearly 2.5 and equals to nearly 5 in columns 1, and 16 these analyses for brick wall thickness 12 cm and 25 cm. In case of uniformly infill buildings, the contribution of higher modes is increased. Axial force in columns increases due to the inclusion of infill in the frames. This alters the yield pattern considerably and building with a smaller aspect ratio may develop a column sway mechanism in ground storey. In case of uniformly infill frame buildings, strength capacity increases than that of bare frame buildings but ductility capacity is reduced. This effect reduces with the increase of the height of the building. In 25cm brick wall thickness the normal force on ground columns exceed the normal force in 12cn brick thickness and lightweight brick walls because of the difference in weight of each case.

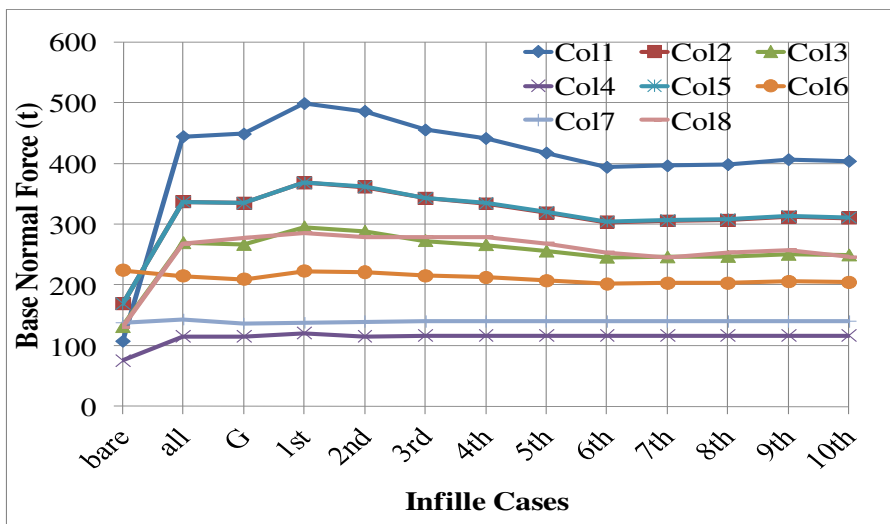

i) Normal Force in col. No. 1 to 8

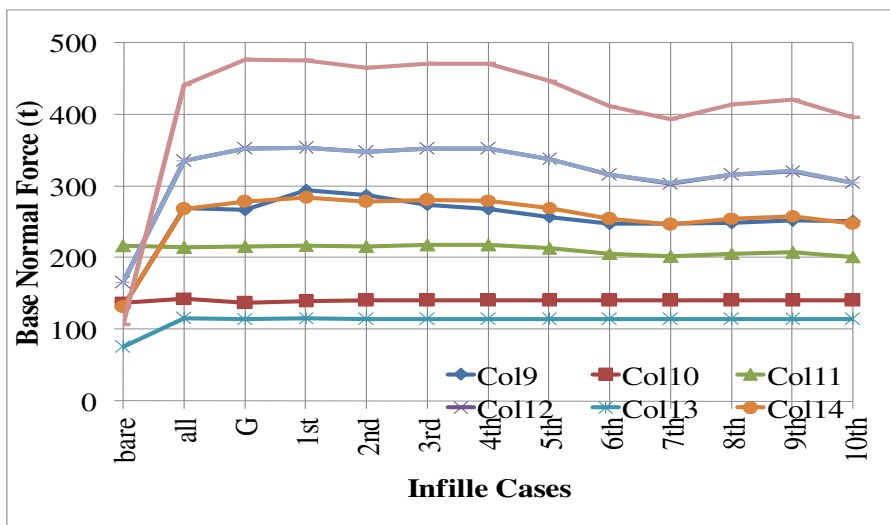

ii) Normal Force in col. No. 9 to 16
 a) 12cm thickness brick walls

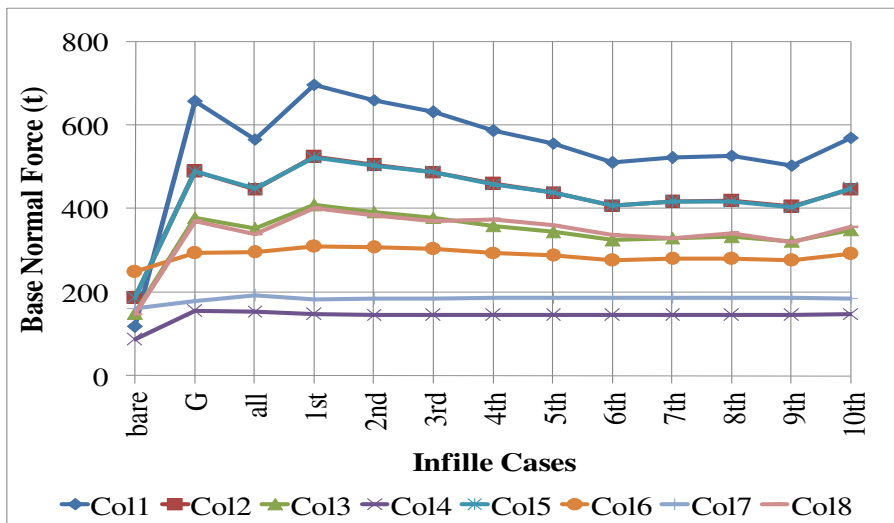

i) Normal Force in col. No. 1 to 8

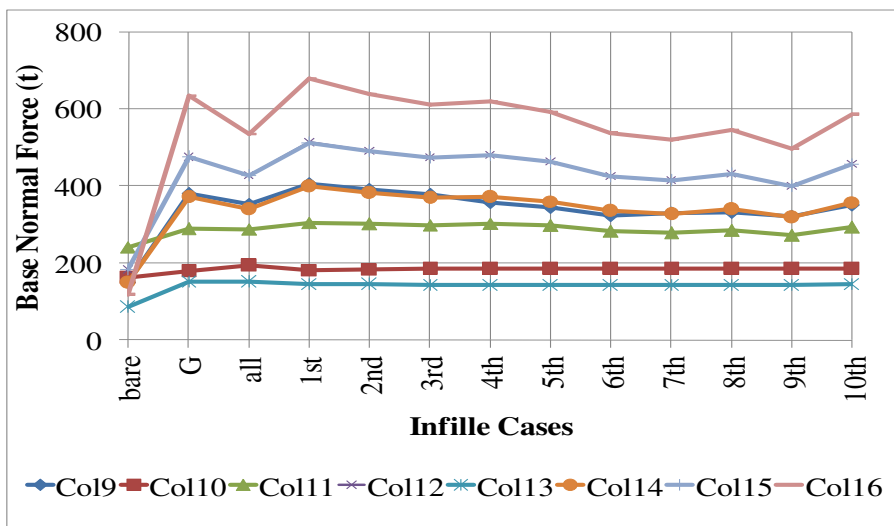

ii) Normal Force in col.No. 9 to 16
 b) 25cm thickness brick walls

Fig. 11. Normal force for base columns

Figure 12 shows base moment in ground columns in various cases of brick wall arrangements and thickness.

Figure (12-a) illustrates the base moment of ground floor columns of 12cm brick wall thickness. In all ground columns in all study cases the ratio of base moment in G case equal to nearly 2 and the ratio between G and 1st cases equal to nearly 1.65. The ratio between base moment in all ground columns in all and G cases equal to nearly 5 in all study cases.

Figure (12-b) illustrates the base moment of ground floor columns of 25cm brick wall thickness. In all ground columns in all study cases the ratio of base moment in G case equal to nearly 3 and the ratio between G and 1st cases equal to nearly 1.5. The ratio between base moment in all ground columns in all and G cases equal to nearly 7 in all study cases.

Figure (12-c) illustrates the base moment of ground floor columns of 20cm lightweight brick wall thickness. In all ground columns in all study cases the ratio of base moment in G case equal to nearly 2 and the ratio between G and 1st cases equal to nearly 1.3. The ratio between base moment in all ground columns in all and G cases equal to nearly 4 in all study cases.

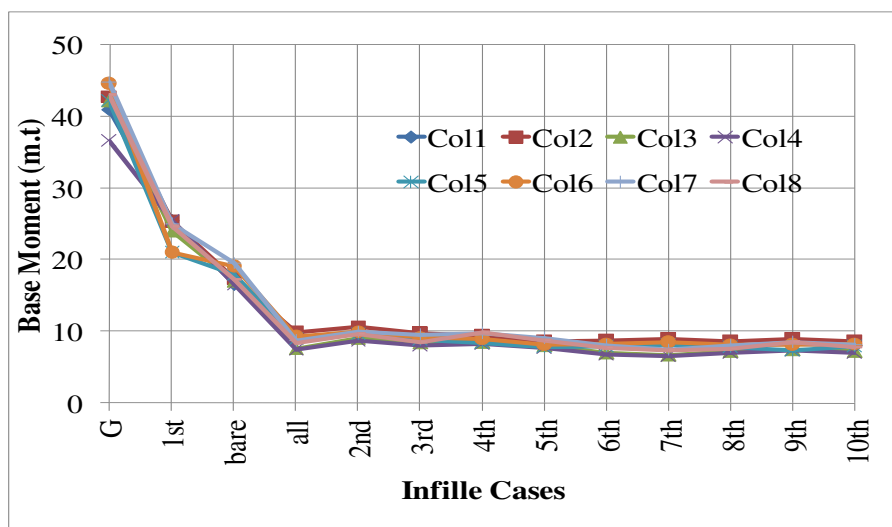

i) Moment in col.No. 1 to 8

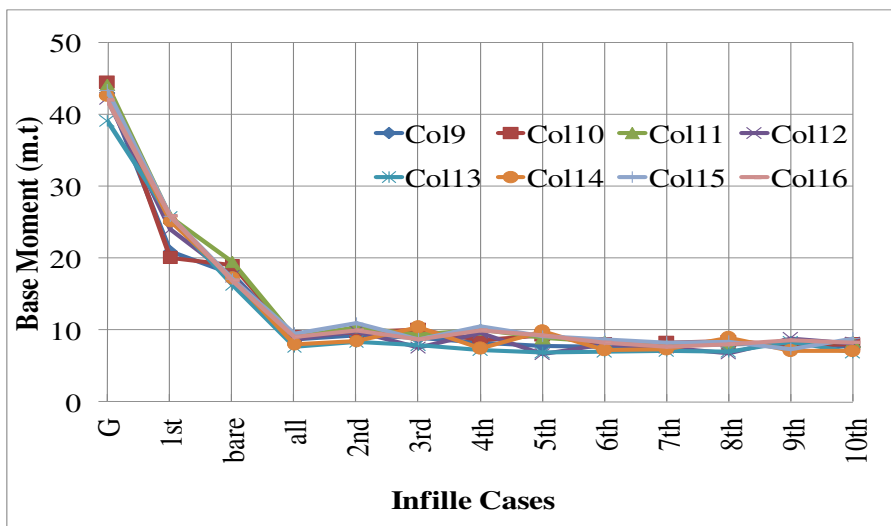

ii) Moment in col. No. 9 to 16
 a) 12cm thickness brick walls

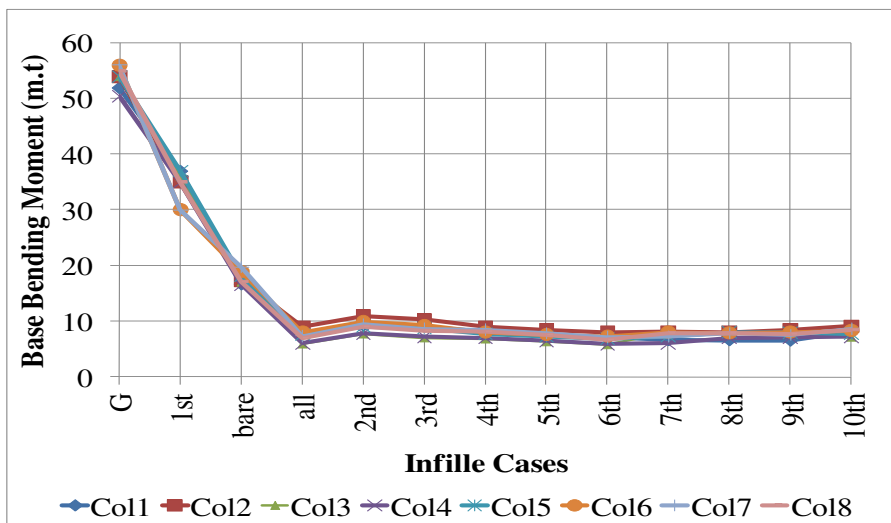

i) Moment on col. No. 1 to 8

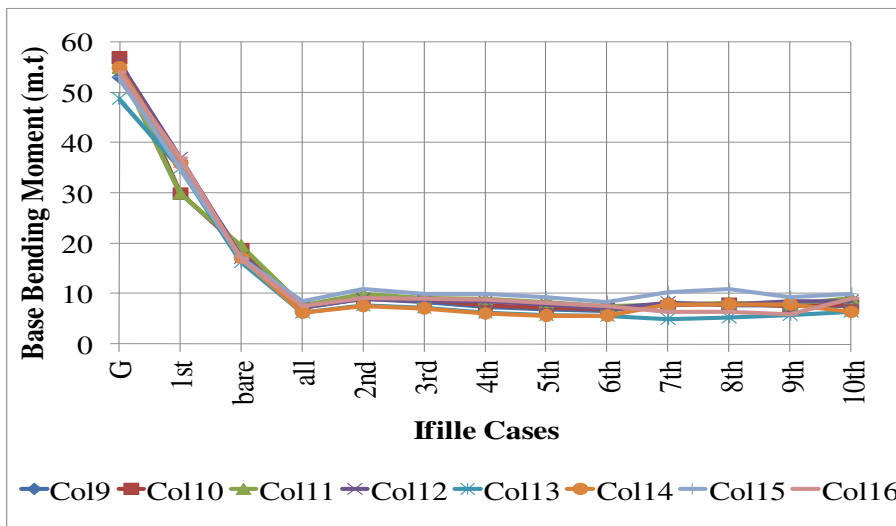

ii) Moment on col. No. 9 to 16
 b) 25cm thickness brick walls

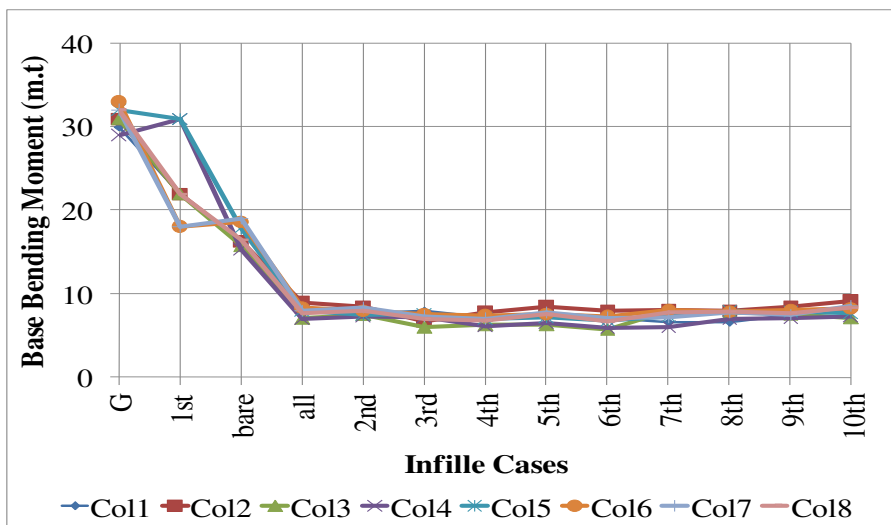

i) Moment on col. No. 1 to 8

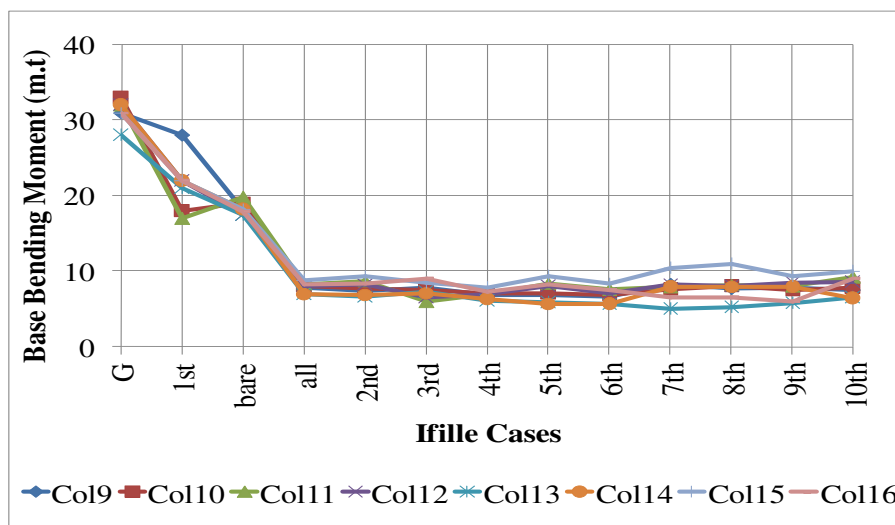

ii) Moment on col. No. 9 to 16
c) 20cm thickness lightweight brick walls

Fig. 12. Bending moment for base columns

Figure 13 illustrates a comparison of shear force and bending moment in columns 5, and 6 (as a larger value in shear between columns) in a different cases of study for each floor with brick wall thickness 12 and 25cm.

Figure (13-a-i,ii) shows the shear force in columns 5 and 6 (brick wall thickness 12cm), it is clear the effect of absence infille in storey on the impact increase of shear force in columns 5, and 6. Two cases were taken to compare the shear force with an impact case (absence of walls in the floor level) the first is bare and the second is all cases. In the absence of infille in ground floor shear in columns 5 and 6 increase by 4 times than bare case and increase bare nearly 3.5 times than a bare case in 1st, 2nd, 3rd, and 4th cases, but in the rest cases increase by nearly 2 times than bare case. Shear force in bare case in G and 1st case less than the individual cases in impact case by 25%, but in the rest cases less than bare case by nearly 40%.

Figure (13-a-iii,iv) shows bending moment in columns 5 and 6, it is clear the effect of absence infille in storey on the impact increase of shear force in columns 5, and 6. Two cases were taken to compare the shear force with an impact case (absence of walls in the floor level) the first is bare and the second is all cases. In absence of infille in ground floor bending moment in columns 5 and 6 increase by 1.5 times than bare case and increase by nearly 4.5 times than the bare case in 1st, 2nd, 3rd, 4th, 5th, 6th, and 7th cases, but in the rest cases increase by nearly 3 times than bare case. Bending moment in bare case in G case less

than the individual cases in impact case by 50%, but in 1st case less than bare case by nearly 10 times and in cases 5th to 8th equal to nearly 2 times, but in cases 2nd, 9th and 10th equal to 4 times.

Figure (13-b-i,ii) show shear force in columns 5 and 6 (brick wall thickness 25cm), it is clear the effect of absence infille in storey on the impact increase shear force in columns 5, and 6. Two case were taken to compare shear force with an impact case (absence of walls in the floor level) bare and all cases. In Fig. (13-b-i) the ratio between the shear force of impact and bare cases for column 5 in cases G, 1st, 2nd, 3rd, 4th, 5th is equal to 4, and in cases 6th, 7th, 8th, 9th, 10th is equal to 3. The ratio between the shear force of impact and bare cases for column 5 in cases G is equal to 50, and in cases 1st, 2nd, 3rd, and 4th is equal to 13, and in cases 5th, and 6th is equal to 20, and in case 7th is equal to 10, and in cases 8th, 9th, 10th is equal to 30. In Fig. (13-b-ii) the ratio between the shear force of impact and bare cases for column 6 in cases G, 1st, 2nd, 3rd, 4th, 5th is equal to 3, and in cases 6th, 7th, 8th, 9th, 10th is equal to 2. The ratio between the shear force of impact and bare cases for column 6 in cases G, 1st, 2nd, 3rd, 4th, 5th, 6th, 7th, 8th, 9th, 10th is equal to 10.

Figure (13-b-iii,iv) show bending moment in columns 5 and 6 (brick wall thickness 25cm), it is clear the effect of absence infille in storey on the impact increase bending moment in columns 5, and 6. Two cases were taken to compare bending moment with a impact case (absence of walls in the floor level) bare and all cases. In Fig. (13-b-iii) the ratio between the bending moment of impact and bare cases for column 5 in cases G, and 6th is equal to 6, and in cases 1st, 6th, 7th, 8th, and 9th is equal to 5, and case 10th is equal to 2. The ratio between the bending moment of impact and bare cases for column 5 in cases G, 6th, 8th, and 9th is equal to 60, and in cases 1st, 2nd, 3rd, 4th, 5th, 7th, 10th is equal to 20. In Fig. (13-b-iv) the ratio between the bending moment of impact and bare cases for column 5 in cases 1st, 2nd, 3rd, 4th, 5th, 6th, 7th is equal to 7, and 8th, 9th cases is equal to 6, in 10th case is equal to 1 and in G case is equal to 3. the ratio between the bending moment of impact and bare cases for column 6 in cases G, 1st, 2nd is equal to 30, in cases 3rd, 4th, 5th, 6th, 7th, 8th, and 9th is equal to 25, and 10th case is equal to 50.

To reduce the impact of the sudden absence of infille some distribution of infille walls will be checked to find the most affected distributed walls with the most effect ratio on the floor to reduce the impact effect and to reduce this effect to arrive to the values of shear force and bending as the bare frame flat slab values. Figure 14 illustrates the suggested arrangements of infille walls in frame flat slab, Fig. (14-i) illustrates an arrangement (inner crosses) with 50% of all floor walls, Fig. (14-ii) core + middle is a 33%, Fig. (14-iii) outer walls is a 50% , and Fig. (14-iv) core is a 16.7% of total infille walls of the floor.

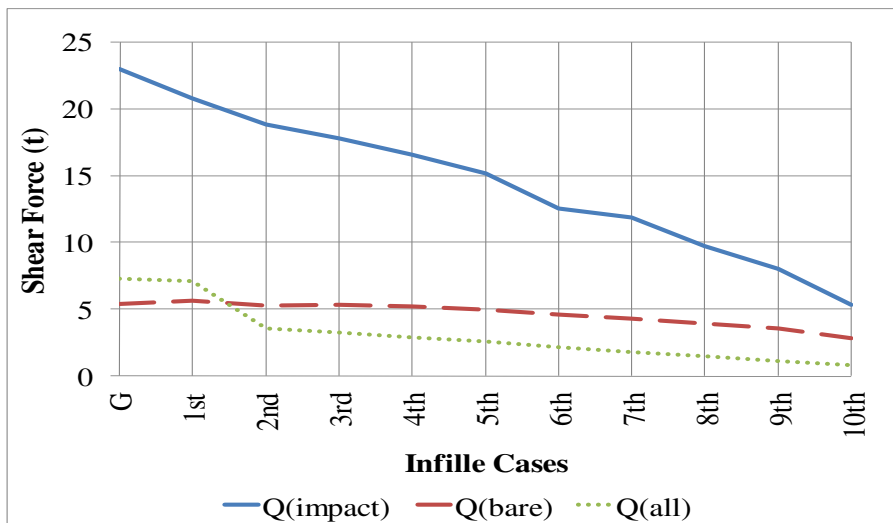

i) Shear Force col. 5.

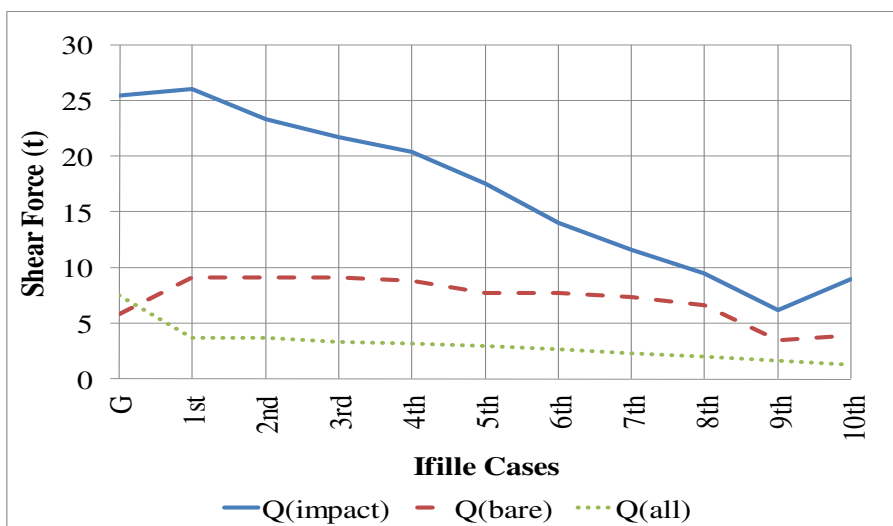

ii) Shear Force col. 6.

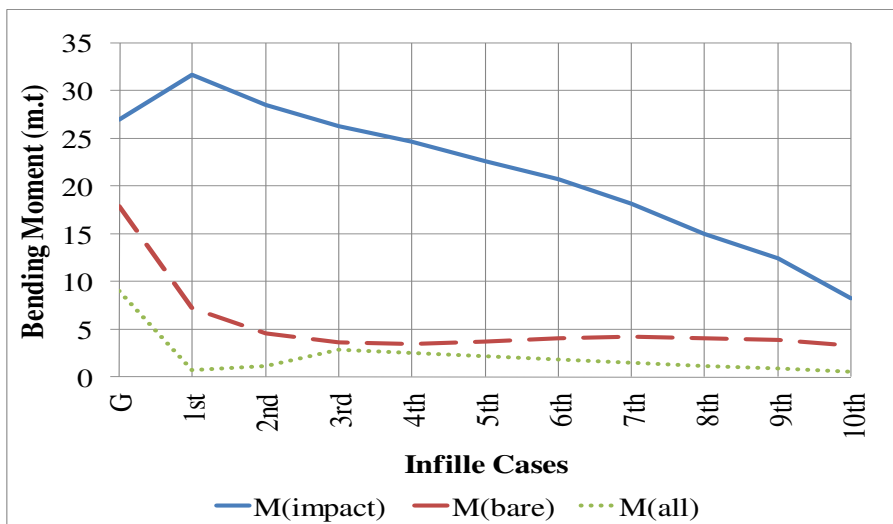

ii) Bending Moment col. 5.

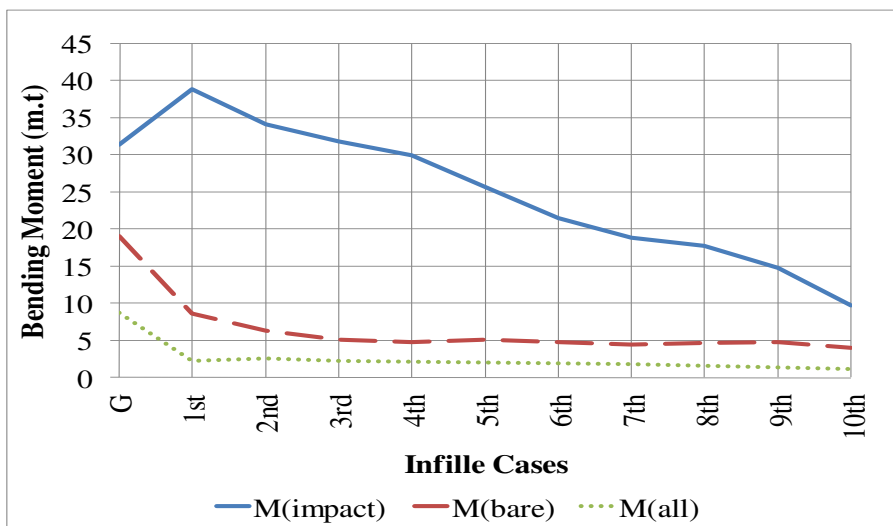

iv) Bending Moment col. 6.
a) 12cm thickness brick walls

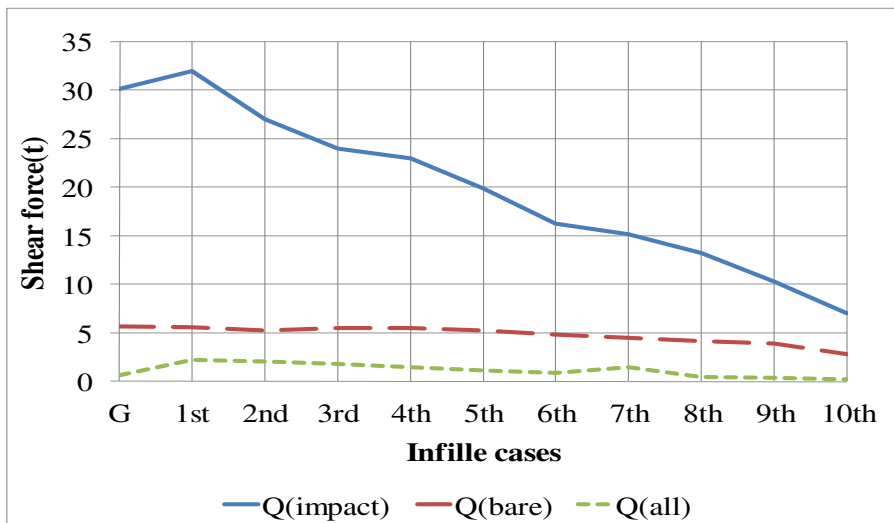

i) Shear Force col. 5.

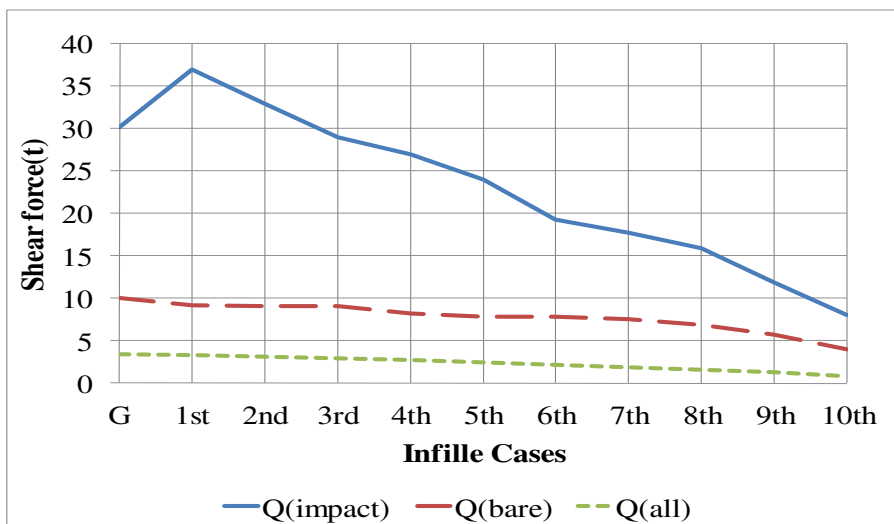

ii) Shear Force col. 6.

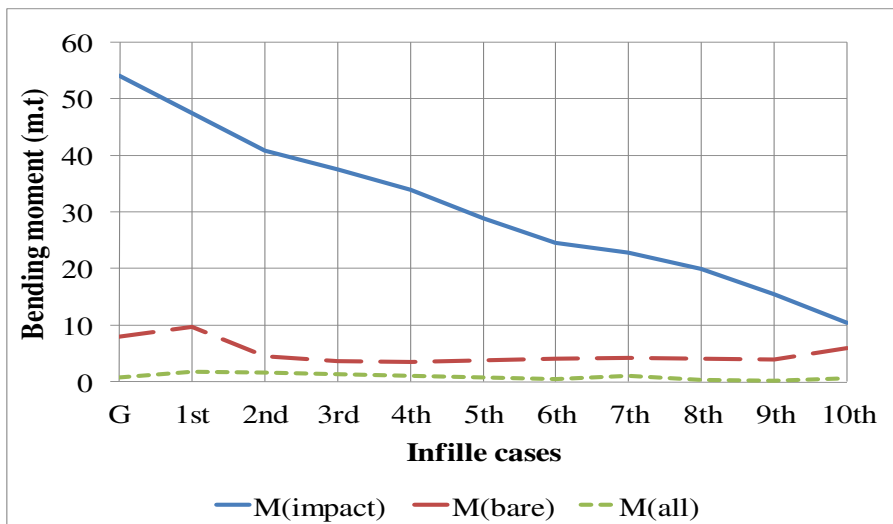

iii) Bending Moment col. 5.

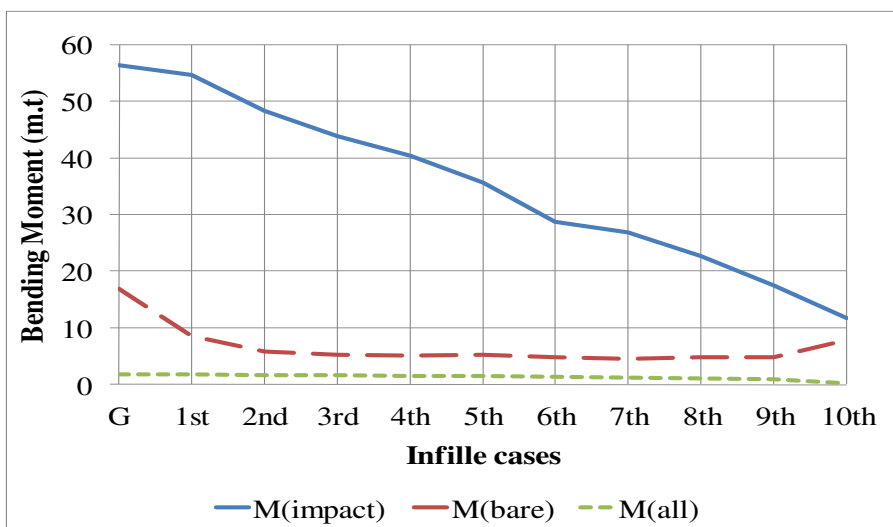

iv) Bending Moment col. 6.
b) 25cm thickness brick walls

Cont. Fig. 13. Impact Shear Force and Bending moment for columns 5, 6

Figure 15 shows the effect of rearrange of infille with specified ratios on columns 5 and 6 on the ground floor. Figure (15-i) illustrates the base shear of column 5 and 6 in different cases of infille wall arrangements. The shear force in columns 5 and 6 in cases inner crosses (50% infille walls) and outer (50% infille walls) is nearly equal to bare case shear force. Figure (15-ii) shows bending moments of column 5 and 6 in different cases of infille wall arrangements. Bending moment in column 5 in cases inner crosses (50% infille walls), outer (50% infille walls) and all are less than bare case bending moment by nearly 15%, and in column 6 in cases inner crosses (50% infille walls), outer (50% infille walls) all, and core + middle outer are less than bare case bending moment by nearly 20% . So, the percentage of brick wall infille can not be less than 33% of the total infille brick walls in the whole floor plane.

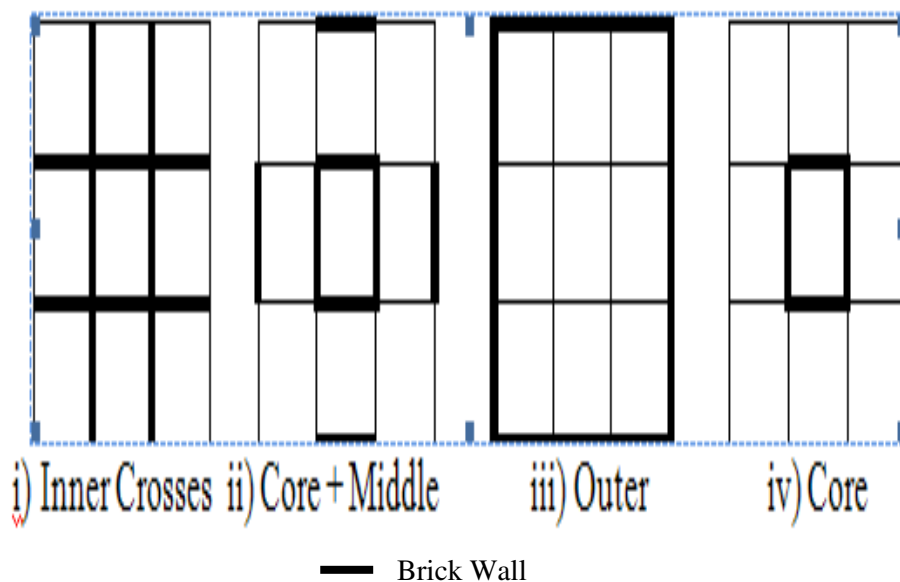
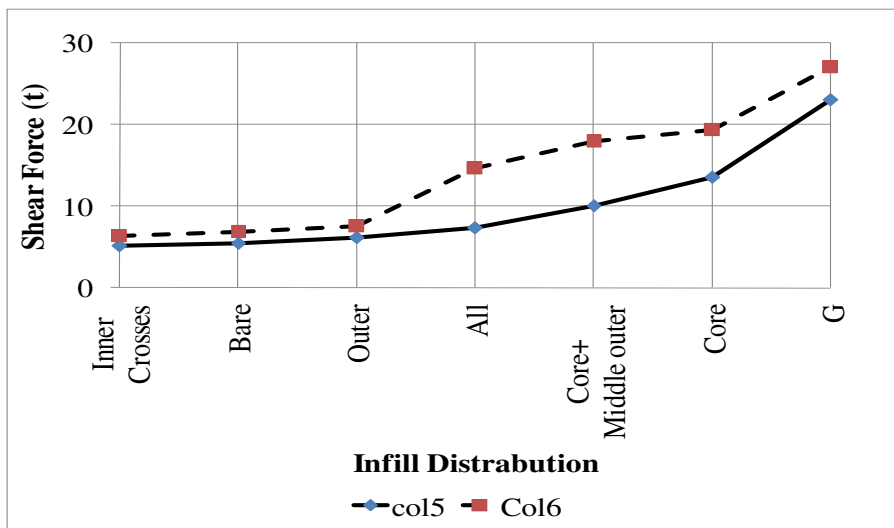
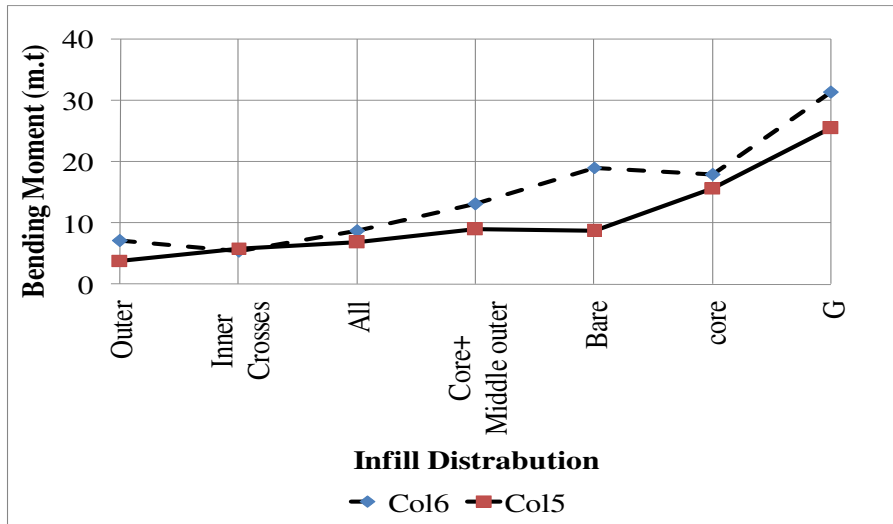

Fig. 14. New Distributions of brick walls in ground floor

Figure 16 displays displacements of each floor with inner crosses brick walls distribution comparison with bare and all cases. The new distribution of walls in each floor gives a flexibility in reduce walls in each floor as architectures demands. The new distribution displacements in each floor are smaller than displacements in bare frame by nearly 0.5 and bigger than all case by nearly 1.75.



i) Base Shear force in columns 5, 6



ii) Base Moment in columns 5, 6

Fig. 15. Effect of distribution of walls in ground floor on Shear Force and Bending moment for columns 5, 6 at 12cm brick walls thickness.

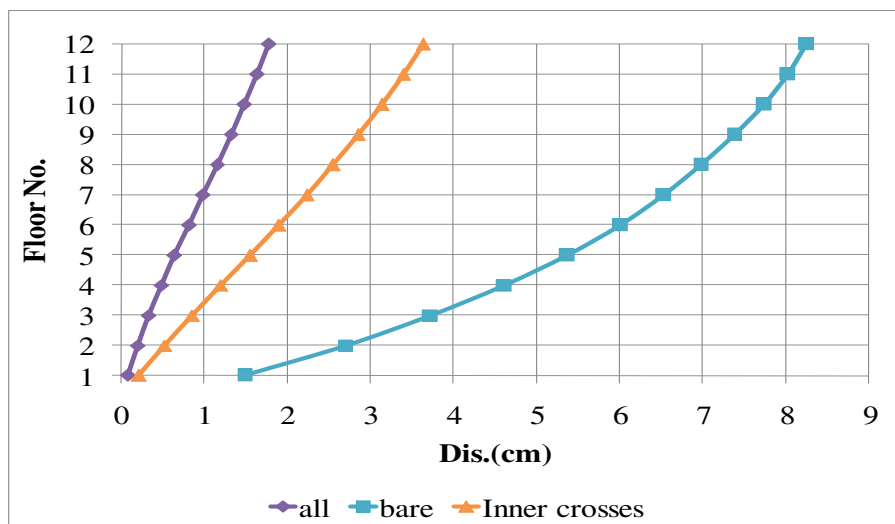
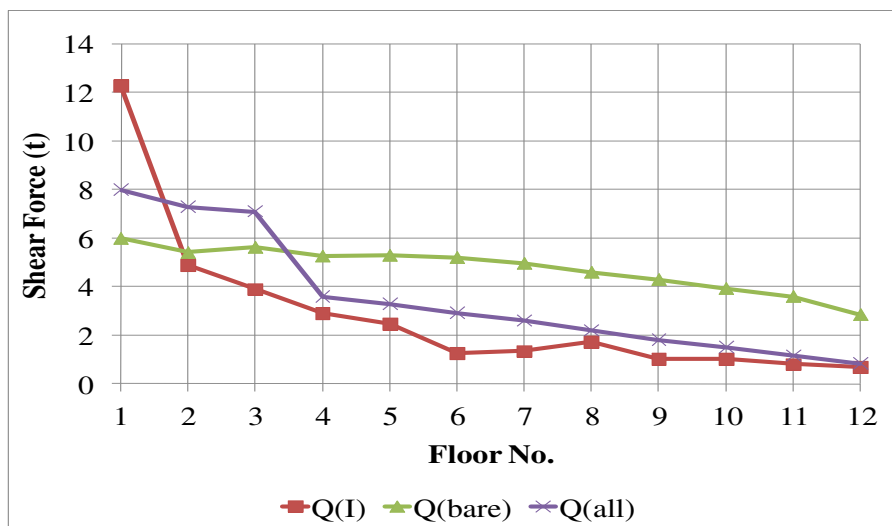

Fig. 16. Displacement of model use inner crosses distribution in each floor with respect to all and bare cases

Figure (17-i,ii) display shear force in columns 5, and 6 in each floor with inner crosses brick walls distribution with respect to bare and all cases. The new distribution of brick walls on each floor seems to be smaller than all case except in the first floor in both columns.

Figure (17-iii,iv) display bending moment in columns 5, and 6 in each floor with inner crosses brick walls distribution with respect to bare and all cases. The new distribution of brick walls on each floor seems to be smaller than all and bare cases for column 5 but, for column 6 bending moment for inner crosses distribution seems to be nearly equal with all case, and also, smaller than bare case.



i) Shear Force in col. 5

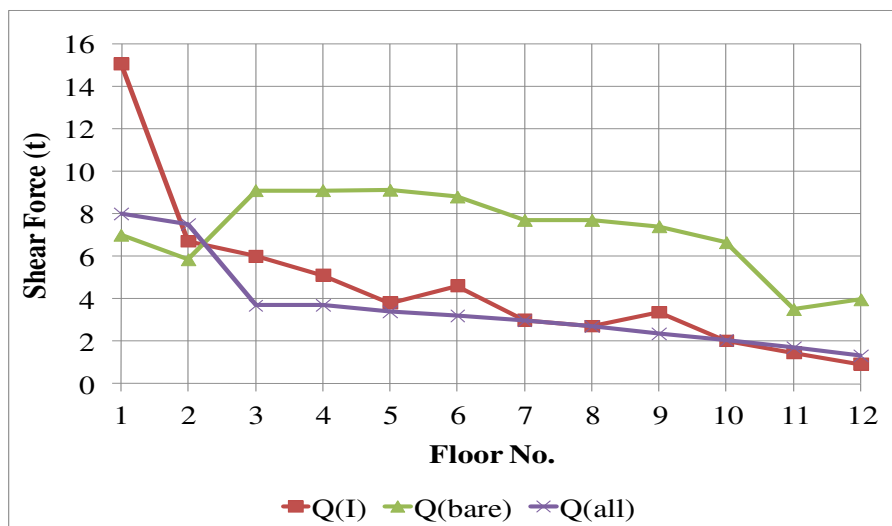

ii) Shear Force in col. 6.

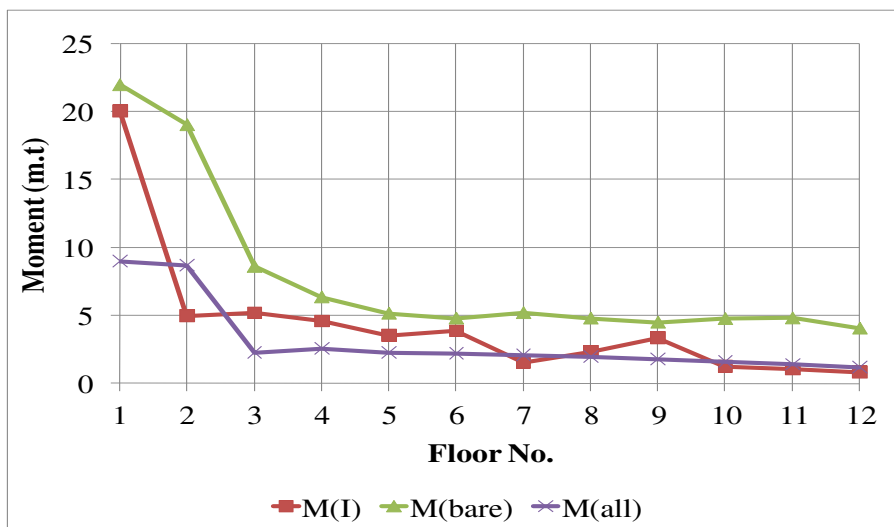

iii) Moment in col. 5

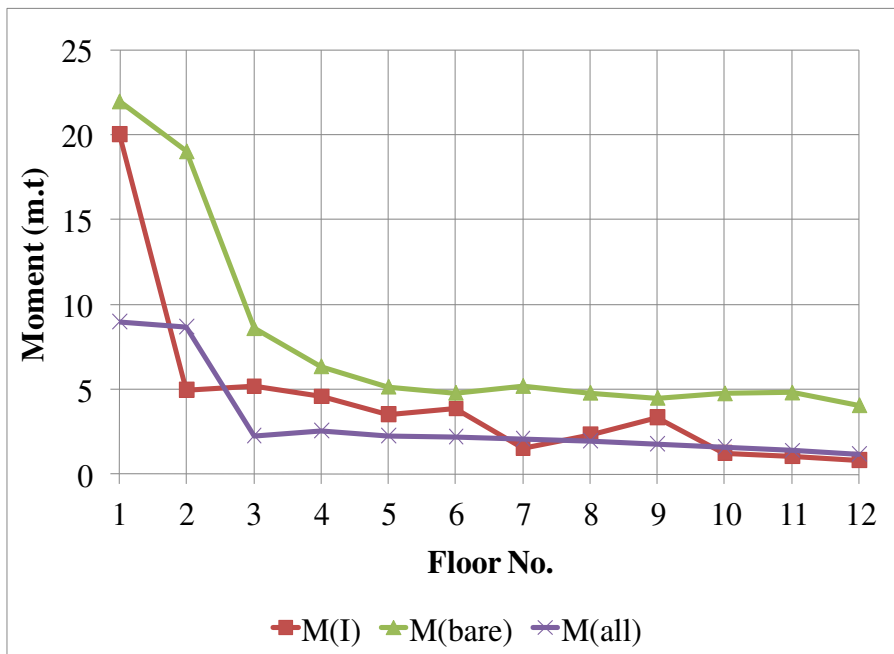

iv) Moment in col. 6.

Fig. 17. Effect of Inner Crosses Distribution of brick walls in each floor on Shear Force and Bending Moment in columns 5, 6 comparisons with bar and all cases

4. Conclusions

Nonlinear time history analysis is carried out on 13 models to study the effects of nonstructural infill walls on the seismic response of flat slab frame buildings, which are analysed with or without infill walls for shopping use or architectures demands, is presented. The stability and integrity of reinforced concrete frames are enhanced with masonry infill walls. The following conclusions can be drawn out as follows:

1. Presence of infill brick walls in the structural analysis of flat slab building frames can modify the global seismic behaviour of frame buildings and alters considerably the top displacement to reach only 17% of the bare frame which may have unacceptable displacement in soft story frame.
2. Irregular distributions of masonry infill wall in elevation (absence infill wall in one floor) result in an increase in the displacement of that floor which reaches 100% to 150% those in upper and lower floors respectively. The stability and integrity of these building frames (bare frames) are enhanced with higher thickness of infill walls which create a diaphragm action. The results showed relatively lower values of top displacements by 20% as the wall thickness varies from 12cm to 25cm.
3. In case of absence of infill brick wall which is widespread for shop use as architectural demands, it is adequate to build 33% to 50% of all wall floor plan lengths where the external faces are tied to the inner core. This regular distribution in building elevation in all stories causes top displacements amounts 40% of that of bare frame.
4. The contribution of infill brick walls demonstrates capability and effectiveness in reducing the shearing forces of columns about 50% to 60% of that induced in the bare frames. Moreover absence of infill walls from one floor has pronounced effects on columns shear forces especially in lower stories (ground and first floor). The shearing force extreme values could reach from 3 to 4 times that induced in the bare frame without infill wall in the ground floor (thickness 12cm). While it reaches 4 to 5 times that of bare frames without infill wall thickness 25cm in the ground floor.
5. The use of infill walls as diaphragms has proved to lead to appreciable reduction in the column base bending moments. Using uniform distribution of infill walls complete in plan and elevation (all model) decreases the base moment by 25% to 50% in external and internal columns respectively compared to the bare frames. The base bending moments in columns are sensitive to absence of infill wall especially in the ground and first floor. The absence infill wall in the ground and first floors will increase the base moment about 1.5 to 3 times corresponding values in bare frame in external and internal columns respectively. The absence of infill wall action in the first floor is more severe where the base moments are about 1.5 to 4.5 times the corresponding values in the internal and external bare columns.
6. The current results proved that the absence of infill walls from the ground and first floors display remarkable increase in axial force as the maximum axial force is

about 1.2 times compared with that generated in all infill wall models in external columns.

7. Finally in the light of the above conclusions, it is recommended to consider the contribution of the infill brick walls in the seismic response of the flat slab building.

References

- [1] Amrhein, J. E., Anderson, J. C. and Robles, V. M., (Nov.-Dec.1985).” Masonry saves lives in Mexico earthquake”. Masonry Design West.
- [2] Angel, R. E., (1994). "Behavior of reinforced concrete frames with masonry infill walls," University Illinois at Urbana-Champaign, Illinois.
- [3] Backes, H.P., (1985).”On the behavior of masonry under tension in the direction of the bed joints” (in German), PhD. Thesis, Aachen University of Technology.
- [4] Bashandy, T., Rubiano, N. R., and Klingner, R. E. (1995). "Evaluation and analytical verification of infilled frame test data." Department of Civil Engineering, University of Texas, Austin, Texas.
- [5] Brzev, S. (2007). “Earthquake-Resistant Confined Masonry Construction”, NICEE, ITTK, Indian, report.
- [6] Chrystomou, C. Z., Gergely, P. and Abel, J. F., (1992).” Nonlinear seismic response of infilled steel frames”. Proceedings of Tenth World Conference on Earthquake Engineering, A. A. Balkema, The Netherlands, vol. 8, pp. 4435–4437)
- [7] Crisafulli, F. (1997). “Seismic Behaviour of Reinforced Structures with Reinforced Masonry Infills”. Phd thesis, University of Canterbury, New Zealand.
- [8] Dhanasekar, M. and Page, A. W., (1986).“The influence of brick masonry infill properties on the behaviour of infilled frames”. Proc. Inst. Civ. Eng. Part 2, **81**, 593–605.
- [9] FEMA-306 FEMA306. (1998). "Evaluation of Earthquake Damaged Concrete and Masonry Wall Buildings."
- [10] FEMA 356.(2000). Guidelines for Seismic Rehabilitation of Buildings, ASCE, Reston VA.
- [11] Fiorato, A. E., Sozen, M. A. and Gamble, W. L., (1970). “An investigation of the interaction of reinforced concrete frames with masonry filler walls”. Report No. UILU-ENG 70-100, University of Illinois at Urbana-Champaign.
- [12] Flanagan, R. D., and Bennett, R. M. (1999). "Bidirectional behaviour of structural clay tile infilled frames." Journal of Structural Engineering (ASCE), 125(3), 236-244.
- [13] Ganz, H.R., and Thürlimann, B.,(1982).” Tests on the biaxial strength of masonry “(in German), ReportNo. 7502-3, Institute of Structural Engineering, Zurich.
- [14] Griffith, M. C., Vaculik, J., Lam, N. T. K., Wilson, J., and Lumantarna, L. (2007). "Cyclic testing of unreinforced masonry walls in two-way bending." Earthquake Engineering & Structural Dynamics, 36(6), 801-821.
- [15] Hamid, A.A., and Drysdale, R.G., (1981).”Concrete masonry under combined shear and compression along the mortar joints”, ACI Journal, p. 1314-320.
- [16] Harpal Singh, Paul, D.K., Sastry, V.V., (1998). Inelastic Dynamic Response of Reinforced Concrete Infilled Frames, Computers and Structures, Vol.69, pp. 685-693.
- [17] Hemant, B. K., Durgesh, C. R., and Sudhir, K. J. (2006). "Code Approaches to Seismic Design of Masonry-Infilled Reinforced Concrete Frames: A State-of-the-Art Review." Earthquake Spectra, 22(4), 961-983.

- [18] Hilsdorf, H.K., (1969). "Investigation into the failure mechanism of brick masonry loaded in axial compression, Designing", Engineering and Constructing with Masonry, p. 34–41.
- [19] Hong hao, Guo-Wei M., and Yong L., (2002). "Damage Assessment of Masonry Infilled RC Frames Subjected to Blasting Induced Ground Excitations", Engineering Structure, Vol.24, No.6, pp.671-838.
- [20] Lam, N. T. K., Griffith, M., Wilson, J., and Doherty, K., (2003). "Time-history analysis of URM walls in out-of-plane flexure." Engineering Structures, 25(6), 743-754.
- [21] Lourenco, P. B. (1996). "Computational Strategies for Masonry Structures", Delf University Press.
- [22] Mander, J. B., Nair, B., Wojtkowski, K., and Ma, J. (1993). "An experimental study on the seismic performance of brick-infilled steel frames with and without retrofit." National Center for Earthquake Engineering Research, State University of New York, Buffalo, New York.
- [23] Nollet, M.J., Smith, B.S., (1998). "Stiffened-Story Wall-Frame Tall Building Structure", Computers and Structure, Vol. 66, No. 2-3, pp.225-240.
- [24] Oliveira, D.V., (2002). "Experimental and numerical analysis of blocky masonry structures under cyclic loading". PhD Thesis. University of Minho.
- [25] Page, A.W., 1981 "The biaxial compressive strength of brick masonry", Proc. Intsn. Civ. Engrs., Part 2, 71, p. 893–906.
- [26] Paulay, T. and Priestley, M. J. N., (1992). "Seismic Design of Reinforced Concrete and Masonry Buildings", John Wiley.
- [27] Pujol S.a, and Fick D. b, (2010). "The test of a full-scale three-story RC structure with masonry infill walls", Engineering Structures 32, 3112-3121.
- [28] Sahota, M.K., Riddington, J.R., (2001). "Experimental Investigation into Using Lead to Reduce Vertical Load Transfer in Infilled Frames", Engineering Structure, No 23, pp.94-101.
- [29] Shing, P. B., and Mehrabi, A. B. (2002). "Behaviour and analysis of masonry-infilled frames." Progress in Structural Engineering and Materials, 4(3), 320-331
- [30] Wesche, K., and Iantzis, A., (1980). "General recommendations for methods of testing load bearing Walls", Materials and Structures, 13(78), p. 433–445.
- [31] "The Egyptian Code for Calculation of loads and Forces in Structural Building Work, ECOL 201" housing and Building Research Center, Cairo, Egypt, September 2008.

مساهمة قواطع المباني غير الانشائية وتوزيعاتها في الاستجابة الزلزالية للمنشآت اللاكمرية
دكتور/حمدي حسين احمد عبد الرحيم^{1*} دكتور/احمد عبد الرحيم فرغلي²

ملخص:

تنفيذ اعمال المباني المتخللة للهيكل الخرسانية كقواطع او فواصل من عدمه فى المنشآت الخرسانية ذات البلاطات اللاكمرية اصبحت عامة فى مصر ومعظم بلدان العالم. يتم تصميم هذه الهياكل الخرسانية طبقا لكود تصميم هذه المنشآت وان احتواء تأثير قواطع المباني غير الانشائية فى التحليل الانشائى لهذه المنشآت اللاكمرية نادرا خاصة عند تعرض هذه المنشآت لهزات ارضية. ومن ثم تضمنت هذه الدراسة تقييم و تميم تأثير قواطع المباني على الاداء الزلزالى لهذه المنشآت الخرسانية اللاكمرية حيث تم اجراء الدراسة العددية على 13 نموذج من هذه المنشآت المجردة من المباني وكذلك بانظمة مختلفة لهذه القواطع باستخدام الحاسب الالى مستخدما طريقة السجل الزمنى الديناميكي لعجلة زلزالية مقدارها 0.50 من قيمة عجلة الجاذبية الارضية والمقدمة من الكود المصرى لحساب الاحمال والقوى فى الاعمال الانشائية والمباني. ويمكن تلخيص النتائج التى تم الحصول عليها كالتالى:

- تضمن السلوك الانشائى للمباني ذات الهياكل الخرسانية اللاكمرية والمعرضة لهزات ارضية لتأثير قواطع المباني تعدل وتطور من الصلابة العامة لمثل هذه المنشآت وذلك بتقليل وتبديل جوهري لازاحة الذروة العلوية الى 17% من قيمة الذروة العلوية للهياكل العارية (الخالية من المباني) التى تكون قيمتها غير مقبولة.
- عدم انتظام توزيع الحوائط فى الطوابق (غياب الحوائط فى احد الطوابق) يؤدى الى زيادة الازاحة الافقية بهذا الدور من 100-150% فى الادوار العلوية و السفلية على الترتيب فاستقرار ورسوخ وثبات وتمامية الهياكل الخرسانية تتحسن باشرارك تأثير سمك قواطع المباني فالمباني سمك 25سم تؤدى الى ازاحة ذروة علوية اقل 20% من نظيرتها فى حالة 12سم. اما استخدام الطوب الخفيف والذى احيانا يوصى به لتخفيف الاحمال على التربة له نفس التأثير السابق على ازاحة الذروة العلوية.
- فى حالة المتطلبات المعمارية بعدم بناء قواطع حوائط يراعى الاتقل نسبة اطوال الحوائط المنفذة فى الدور الواحد عن 33-50% من اطوال الحوائط الكلية بالدور الواحد ويفضل تنفيذها بين الاعمدة الداخلية والربط الخارجى لمحيط المبنى وفى حالة ثبات هذه النظام (Inner crosses) فى جميع الادوار تقل ازاحة الذروة العلوية الى 40% من قيمتها فى حالة الهياكل الخرسانية المسلحة العارية من المباني.
- يلعب اشترك انتظام جميع الحوائط فى المسقط الافقى والراسى (نموذج all) دور هام فى تقليل القوى القاصة على الاعمدة بنسبة 50-60% من القيمة الناجمة فى الهياكل العارية. وغياب الحوائط فى احد الادوار يسبب زيادة كبيرة فى القوى القاصة بالاعمة خاصة غياب الحوائط سمك 12سم عن الادوار السفلية بالذات الارضى يرفع القص الى 3-4 اضعاف مثلتها فى الهياكل الخرسانية العارية ويرفعه الى 4-5 اضعاف فى حالة سمك الحوائط 25سم.
- عزوم الانحناء القاعدية بالاعمة تكون شديدة الحساسية لغياب تأثير قواطع الحوائط بين الاعمدة فى المسقط الافقى وثبات هذا النظام فى جميع الادوار يؤدى الى نقص عزوم الانحناء القاعدية من 25% الى 50% نظيراتها فى الهياكل العارية وغياب قواطع الحوائط عن الدور الارضى يرفع عزوم الانحناء من 1.5 الى 3 اضعاف نظيرتها بالاعمة الداخلية والخارجية بالهياكل العارية على الترتيب.

بينما غياب الحوائط من الدور الاول العلوى يرفع عزم الانحناء القاعدية من 1.50 الى 4.50 قيمتها فى الاعمدة الداخلية و الخارجية للهياكل العارية على الترتيب.

- اثبتت نتائج البحث ان غياب تأثير المبانى بالدور الارضى و الاول العلوى له تاثير ملحوظ على القوى العمودية فى الاعمدة بزيادة القوى العمودية 20% عن نظيرتها الناجمة فى حالة بناء الحوائط فى جميع الادوار (نموذج all).