

## REMEDIAL STRATEGIES OF THE FAULTS IN THE DRIVE CIRCUIT OF AIRCRAFT FUEL PUMP

---

**Ahmed AbdEl-malek AbdEl-hafez**

Lecturer in Electrical department, faculty of engineering, Assiut University  
P.O. 71561, Tel : +2 088 2411038 [Elhafez@aun.edu.eg](mailto:Elhafez@aun.edu.eg)

(Received November 3, 2009 Accepted December 31, 2009).

*This paper is aimed at examining the performance of H-bridges supplying fault-tolerant Permanent magnet machine in the aircraft fuel pump under short circuit condition. A significant DC component flows in the windings with a subsequent of saturation and higher iron losses, which possibly deteriorates the performance of the fuel pump. Expressions are derived to predict the inverter current during the fault. Also, the paper discusses all the possible remedial actions and highlights the most suitable one.*

### 1- INTRODUCTION

Aerospace applications require fault-tolerant drives that might be able to continue operating in an adequate manner after the development of a sustained fault [1-3]. An adequate manner means that the drive after the fault experiences almost no reduction in the torque capability [4, 5].

The Switched Reluctance (SR) machines have been considered for these high performance applications due to their inherent fault tolerant performance [1, 2, 6], as each phase is fed from a separate H-bridge. However, the SR machines have relatively reduced power density compared to other machine types [7].

The Permanent Magnet (PM) machines typically offer higher power to mass ratio than the SR machines; however their fault-tolerant capabilities are poor [1,2, 6-8].

Recently the fault-tolerance strategy has been introduced into the PM machines. This is achieved by implementing the machine using the modular approach [1, 6-8]. The modular approach implies that each phase in the machine is electrically, magnetically and thermally isolated from the remaining phases. Moreover, the phase has a high reactance around 1 pu. This is to limit the short circuit to the rated current level, which allows the machine operation with a sustained fault without exceeding the windings thermal limit. The fault-tolerant PM machine has typically a high phase number, which permits the machine introducing a reasonable amount of power/torque after losing one or more phases. The modular approach is extended to the drive circuit; each phase of the machine is connected to a separate single-phase H-bridge converter. The converters are thermally and electrically isolated from each other; this is to ensure that the fault in a converter module is not propagate to the remaining modules/phases [1, 6-8].

A six-phase fault-tolerant PM machine driven from six single-phase H-bridges inverter is proposed to drive the aircraft fuel pump[1,7], the machine parameters [1] are given in Table 1.

**Table 1:** Machine parameters [1]

Rated power	16kW
Number of phases	6
Number of poles	8
Operating speed	13000 rpm
RMS of motor back emf at operating speed	140.64 V
RMS rated current	19
Per-phase inductance	1.28mH
Per-phase resistance	156m $\Omega$
Phase separation	60 <sup>0</sup>

Many faults are likely to occur in the windings of the PM machine or in the drive circuit. The principal faults within the PM machine as: winding short circuit at the terminal and turn-to-turn short circuit are adequately covered in [1, 2, 6, 7]. However, the faults in the drive circuit (H-bridge) such as: power device short and open circuit are not satisfactorily addressed. No Mathematical manipulation or comprehensive discussion of the remedial strategies are introduced [1, 2, 6, 7].

Therefore, the aim of this paper is to examine thoroughly the faults in the drive circuit of the PM machine used to drive the aircraft fuel pump and to introduce expressions, which predict the inverter current during the fault with a reasonable degree of accuracy as the results shown. Moreover, this paper discusses all the possible remedial actions and highlights the most suitable one.

## 2- POWER DEVICE SHORT CIRCUIT FAULT

Figure 1 shows the per-phase equivalent circuit of the PM drive and the area of the interest relating to a short circuit switching element within the inverter. The fault may be due to internal defects in the switch. The phase of the PM motor is modelled as sinusoidal ac voltage source in series with the phase resistance and inductance. The phase is connected to single-phase H-bridge inverter.

The conventional control strategy for the fault shown in Figure 1 is blocking all gate signals; however this action produces a significant DC offset in the inverter output current.

In the following analysis, the inverter current is assumed sinusoidal and the motor back emf is taken as a reference.

In the positive half cycle of the motor emf switches 1 and 2 should conduct; however, triggering switch 1 is not preferable as this would result in a significant shoot-through leading to damage of the switching device and the DC-link. Obviously the degrees of freedom are limited with a short-circuited switch in the drive circuit.

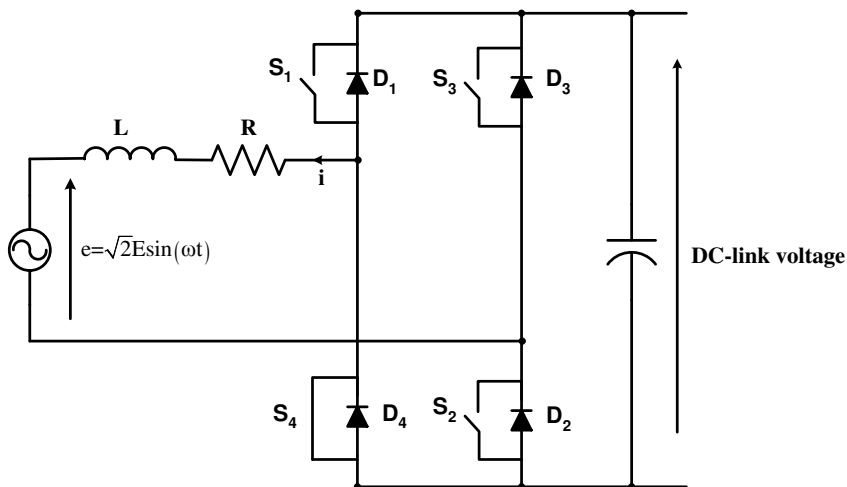

**Figure 1:** Per-phase equivalent circuit of the PM drive with a short circuit fault in switch 4

Blocking the gate signals causes the current to circulate between the motor phase, switch 4 and diode 2 placing a short circuit on the machine phase. This case is depicted in the equivalent circuit in Figure 2.

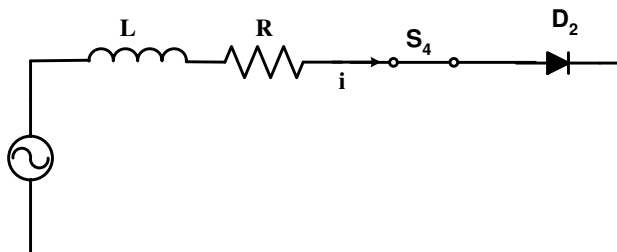

**Figure 2:** Current path during the positive half cycle of the motor emf

The voltage across the phase winding is the emf; therefore the current builds to a high value. The circuit in Figure 2 can be expressed mathematically by

$$L \frac{di}{dt} + iR = \sqrt{2}E \sin(\omega t) \tag{1}$$

Assuming that the initial condition is zero, the inverter current is :

$$i = \frac{\sqrt{2}E}{Z} \sin(\theta) e^{-\frac{L}{R}} + \frac{\sqrt{2}E}{Z} \sin(\omega t - \theta) \tag{2}$$

where,  $Z = \sqrt{(\omega L)^2 + R^2}$ ,  $\theta = \tan^{-1}\left(\frac{\omega L}{R}\right)$ , and  $0 \leq t \leq \frac{\pi}{\omega}$ .

At the end of the positive half cycle, the current can be obtained by setting  $\omega t = \pi$ ,

$$I_1 = \frac{\sqrt{2}E}{Z} \sin(\theta) e^{-\frac{\pi L}{\omega R}} + \frac{\sqrt{2}E}{Z} \cos(\theta) \tag{3}$$

During the negative half cycle of the motor emf, the current is large and positive; therefore, the current still flows through diode 2 and switch 4 applying negative voltage across the phase winding, which reduces the current. Figure 2 and (1) are still depicting this case; however, the initial condition here is  $I_1$ .

Redefining the time origin at the beginning of the negative half cycle and solving (1) with  $I_1$  as an initial condition, the inverter output current is still given by

(2); where  $t$  in this case is  $\frac{\pi}{\omega} \leq t \leq \frac{2\pi}{\omega}$ . Therefore, (2) gives the inverter current at any

instant over the whole cycle of the motor emf. (2) indicates that the current reduces during the negative half cycle as a result of the negative volt-time area and approaches zero before the end of this half. If the current tries to reverse, diode 3 and switch 4 conduct; however the current will be driven back to zero, as this combination connects the motor to the DC-link in such way to reduce the current. Therefore, the current is likely to settle around the zero until the next positive half cycle of the motor emf.

Basically in the inductive circuit the DC offset decays naturally to zero due to the presence of the resistance. However, for a faulted device in H-bridge inverter supplying PM motor the presence of the diodes prevents the current going negative and forces it to zero. Therefore, a DC component is sustained in the inverter output current, as the circuit reset each cycle.

Figure 3 shows the inverter output currents calculated from equ. (2) and simulated using Micro-cap for the machine parameters reported in Table 1.

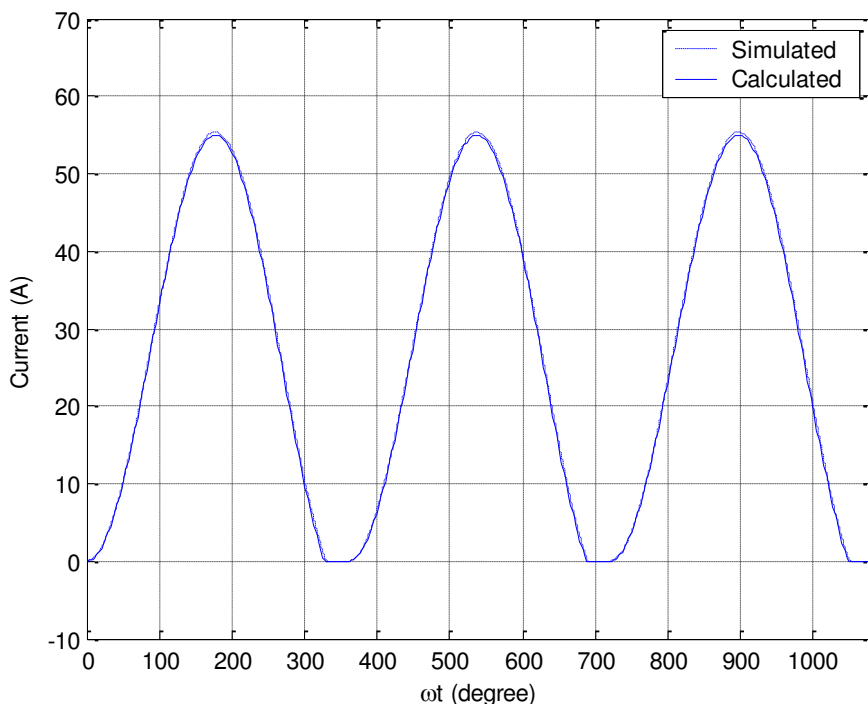
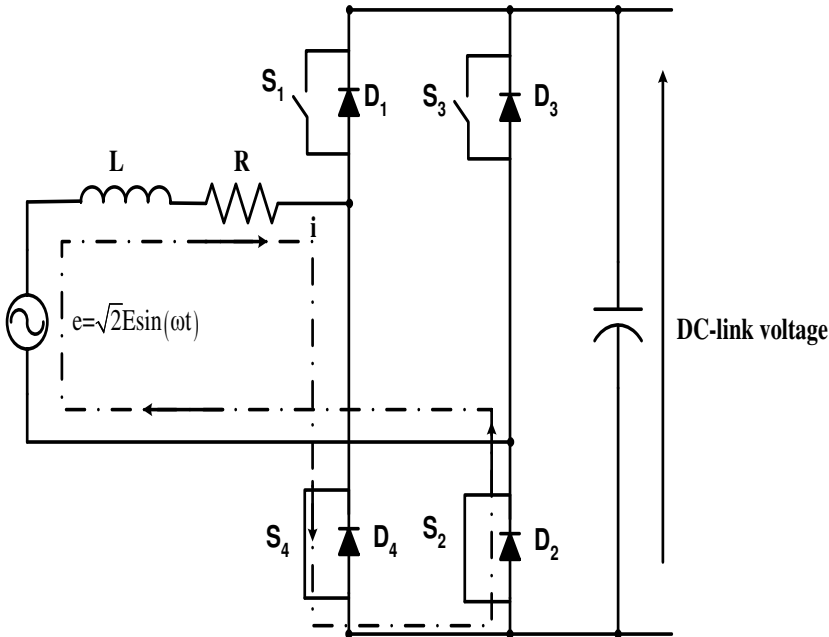

**Figure 3:** Inverter output current simulated (dash-dotted) and calculated (solid) during the short-circuit fault of a H-bridge switch

### 3- THE REMEDIAL STRATEGIES OF POWER DEVICE SHORT CIRCUIT FAULT

The control options for a short circuit device in the H-bridge inverter are limited. Triggering switch 1 is not desirable option as it causes shoot through and damage the DC-link and the switching elements. Activating switch 3 transfers the current from diode 2. However, this strategy increases the magnitude of the current significantly, as the DC-link now is adding to the motor emf.

Activating switch 2 continuously seems to be the best option, as this creates a continuous short circuit on the machine phase, which removes the sustained DC components from flowing into the phase winding and creating a significant iron losses within the machine. Moreover, for this kind of fault-tolerant drive as mentioned before the short circuit current is no more than the rated current, which ensures that the thermal limits of the phase windings are not exceeded. However, continuously triggering switch 2 increases the conduction losses due to  $360^\circ$  conduction. The proposed control strategy is shown in Figure 4.



**Figure 4:** The proposed control strategy, the current path (dash-dotted)

The current path in the proposed control action is shown in blue in Figure 4. Figure 5 shows the motor back emf and the current calculated and simulated after deploying the proposed control strategy.

The current lags the back emf by nearly  $90^\circ$  as shown in Figure 5, which owes to the high phase inductance. Therefore, the average braking torque produced by the faulted phase is nearly zero. This is shown in Figure 6, where the instantaneous developed torque is plotted for pre, during and post fault states.

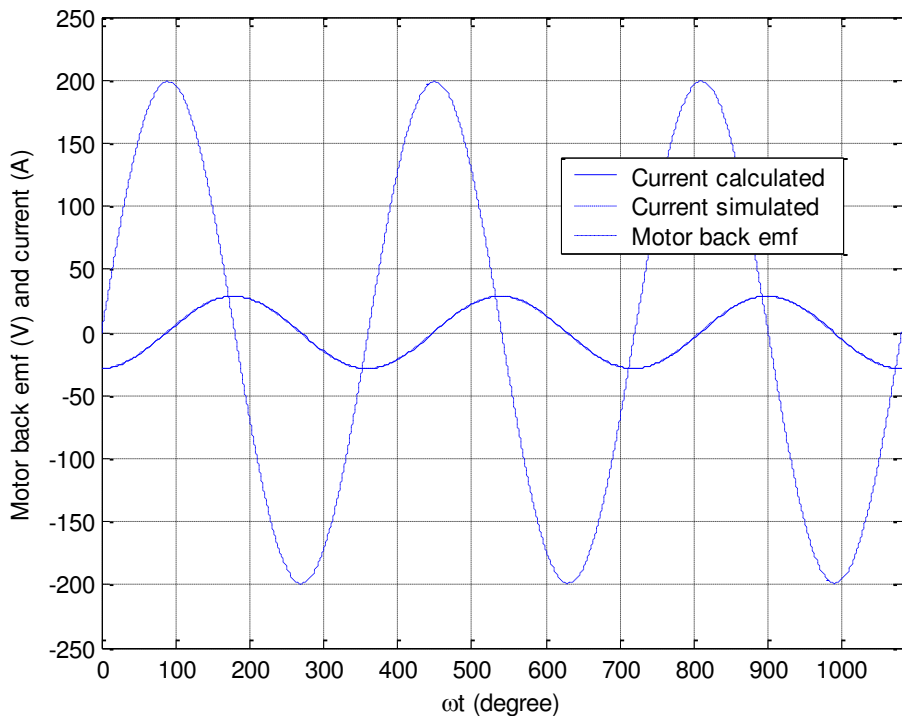

**Figure 5:** Inverter output current simulated (dash-dotted), calculated (solid) and the motor back emf (dotted) with the proposed control strategy

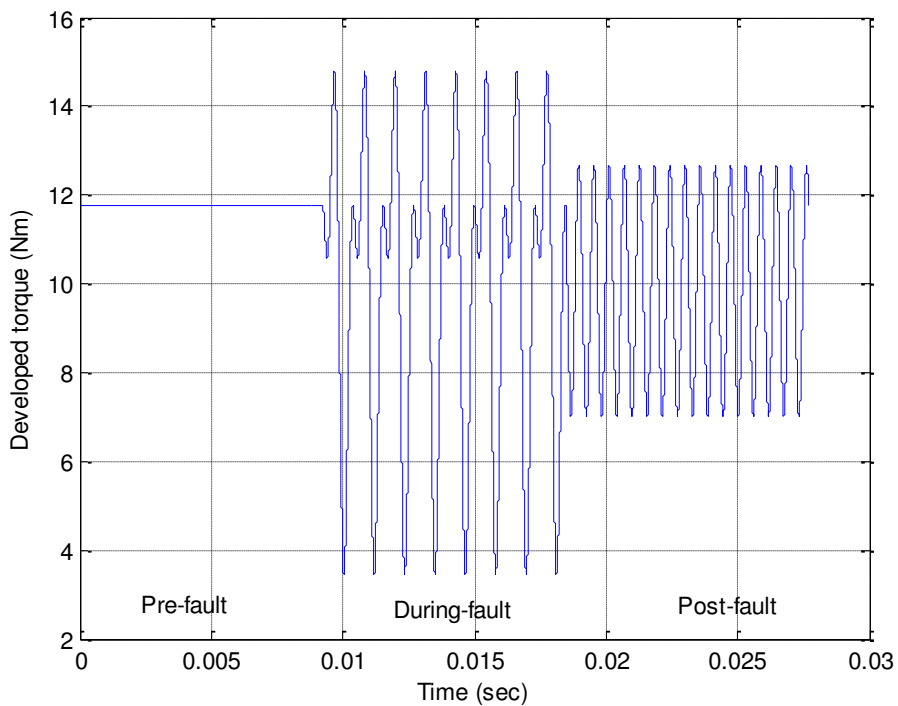

**Figure 6:** The motor developed torque pre, during and post the fault

In the pre-fault state, when the six phases share the load equally, the instantaneous developed torque is constant at 11.73Nm. However, when a device in an H-bridge develops a short-circuit fault and inappropriate control action was taken, large ripples are present in the instantaneous developed. These ripples could be destructive for the load and the motor mechanical parts. These ripples are reduced significantly with the proposed control strategy. The proposed control technique, however, reduces the torque capability as shown in Figure 6, where the average value of the developed torque in the post-fault state is around 9.8 Nm as compared with 11.73 Nm in the pre-fault state.

## 4 - CONCLUSION

1. A sustained DC component in the phase current results from a short circuit failure of one of the switching elements of the H-bridge attached to this phase.
2. The DC component increases the losses, reduces the drive torque capability and saturates the machine irons.
3. If converter control is lost, the free-wheeling diodes in the circuit prevents the DC component of current from decaying as would naturally occur in normal AC inductive loads. The presence of these converter diodes creates a natural reset every cycle and actively prevents the machine winding current from reversing.
4. In a faulted state, the circuit has limited control options.
5. It seems preferable to continuously gate the switching element adjacent to the faulted device to form a symmetrical short circuit across the machine windings, which should allow the DC component of current to decay. However, this assumes the control system and gate circuits remain healthy and available in the event of a faulted switching element.

## 5- ACKNOWLEDGMENT

The author is deeply acknowledged to Professor Mazen M. AbdElsaleem for his significant contributions.

## REFERENCES

- [1] A. G. Jack, J. A. Haylock, B. C. Mecrow, and D. J. Atkinson, "Operation of Fault Tolerant Machines with winding Failures " *IEEE transactions on Energy Conversion* vol. 14, pp. 1490-1495, December 1999 1999.
- [2] B. C. Mecrow, D. J. Atkinson, A. G. Jack, S.Green, and J. A. Haylock, "THE NEED FOR FAULT TOLERANCE IN AEROENGINE ELECTRIC FUEL CONTROL SYSTEM," *IEE Electric Power Applications*, vol. 20, pp. 1/9-5/9, 1999.
- [3] R. I. Jones, "The More Electric Aircraft: the past and the future?," *IEE Colloquium on Electrical Machines and Systems for the More Electric Aircraft*, pp. 1/1-1/4, 1999.

- [4] R. N. Argile, B. C. Mecrow, D. J. Atkinson, A. G. Jack, and P. Sangha, "reliability analysis of fault tolerant drive topologies," in *the Proceeding of The 4th IET International Conference on Power Electronics, Machines and Drives, 2008.PEMD 2008*, 2008, pp. 11-15.
- [5] R. V. White and F. M. Miles, "Principles of fault tolerance," in *the Proceeding of Eighth Annual Applied Power Electronics Conference and Exposition, 1996. APEC '96*, 1996, pp. 18-25.
- [6] A. G. Jack, B. C. Mecrow, and J. A. Haylock, "A comparative study of permanent magnet and switched reluctance motors for high-performance fault-tolerant applications," *IEEE Transactions on Industry Applications*, vol. 32, pp. 889-895, July/August 1996 1996.
- [7] A. G. Jack, B. C. Mecrow, J. A. Haylock, and J. Coles, "Fault-tolerant permanent magnet machine drives," *IEE Electric Power Applications* vol. 143, pp. 437-442, November 1996 1996.
- [8] A. J. Mitcham, G. Antonopoulos, and J. J. A. Cullen, "Favourable slot and pole number combinations for fault-tolerant PM machines Favourable slot and pole number combinations for fault-tolerant PM machines," *IEE Electric Power Applications*, vol. 151, pp. 520-525, 9 September 2004 2004.

### معالجة الأخطاء في دائرة تغذية مضخة وقود في الطائرات

يدرس هذا البحث " المغيرات H" التي تغذي محرك دائم المغناطيسية , متحمل للأخطاء في مضخة الوقود الخاصة بالطائرات تحت حدوث قصر في أحدي المفاتيح الموجودة في فنطرة H . يصاحب هذا القصر مرور تيار له مركبة ثابتة مما قد يؤدي إلي حدوث تشبع و مفايد كثيرة داخل المحرك . تم في هذا البحث أستنتاج معادلات التيار تحت هذا النوع من الأخطاء و كذلك تم مناقشة كل وسائل المعالجة مع التركيز علي أنسب أسلوب منهم.